

Road Safety Learning Resources for Schools

Aligned with
Manitoba's Health
Education/Physical
Education Curriculum

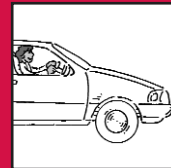

Kindergarten

Manitoba
Education,
Training
and Youth



**Manitoba
Public Insurance**

Acknowledgements

Manitoba Public Insurance (MPI) and the Government of Manitoba Education, Training and Youth (MET & Y) gratefully acknowledge the participation and support of the various government agencies, community organizations and people who contributed so generously of their time and expertise in the development of the Children's Traffic Club and the school-based Road Safety Learning Resources Program. Also, we would like to acknowledge the Scottish Road Safety Campaign and Alberta Transportation and Utilities as well as other counterpart road safety organizations in other jurisdictions for graciously sharing their resources.

Many people within MPI, MET & Y and the wider professional community have contributed immensely to this program.

In particular, we would like to express our special thanks to the following:

Program Development/Advisory Team

James Aryee	Program Leader - Manitoba Public Insurance
Zdenka Melnyk	Manager, Advertising - Manitoba Public Insurance
Jacques Dorge	Physical/Health Education Consultant - Manitoba Education, Training and Youth
Heather Willoughby	Physical/Health Education Consultant - Manitoba Education, Training and Youth

Writers

Dawn White	White and Harvey Educational Consultants and Program Designers
Debbie Kaatz	Independent Writer

Editors

Dawn White	White and Harvey Educational Consultants and Program Designers
Dexter Harvey	White and Harvey Educational Consultants and Program Designers

Early Years Pilot Group: Grades K – 4 Pilot Teachers

Urban: Bairdmore School, Fort Garry School Division No. 5

Donna Keating	Maureen Tisdale	Norma Armstrong
Sophie Elgar	Jennifer Gibb	

Rural: Gimli Early/Middle Years School, Evergreen School Division No. 22

Nataly Sucharyna	Nancy Johnson	Ellen Gergatz
Claire Solmundson	Lisa White	Linda Orestes
Rossana Cuthbert	Mike Sucharyna	

First Nations: Lake Manitoba School, Individual Band Operated School

Joanna Racette	Emma Hogg
Beatrice Missyabitt	Margaret Houle

Our special thanks go to all the students and teachers who participated in piloting the materials in the classrooms. Their feedback has contributed immensely to the development of a more teacher/student user-friendly resource package for Manitoba Schools.

Stay Safe at all times,
Paul Allen
Manager, Road Safety Department
Manitoba Public Insurance

KINDERGARTEN

TABLE OF CONTENTS

	Pages
Introduction	K - 4
Scope and Sequence	K - 6
Parent Letter	K - 9
Learning Activities:	
1. What Is Traffic?	K - 10
2. Road Safety Dot-to-Dot	K - 14
3. Traffic Light	K - 22
4. Traffic Signs – Song 1	K - 24
5. Do You Know The Road Safety Rules?	K - 26
6. Crossing Safely – Song 2	K - 30
7. Where’s The Road Danger?	K - 33
8. I Spy The Road Danger	K - 36
9. Red Light, Green Light	K - 38
10. Who Can Help Us? Riddles	K - 39
11. Safety Helpers – Song 3	K - 44
12. Safety Maze	K - 46
13. Safe Places	K - 49
14. I Spy	K - 52
15. Practice – Road Safety Walk	K - 54
16. The Road Safety Walk Game	K - 61
Assessment Tool – Teacher Road Safety Checklist	K - 63

INTRODUCTION

We are delighted to welcome you and your class to partake in the school-based road safety learning program. This program is a continuation of the Children's Traffic Club, which is now available in day care centres across Manitoba.

Unfortunately, the leading cause of death and injury for children 5 – 14 years of age in Manitoba is road-related. In many instances, simple precautions could have prevented the occurrence and severity of such incidents.

Research studies have shown that children's perceptions and sensory skills may sometimes put them at a disadvantage in traffic situations. In most instances, young children:

- Experience difficulties in judging speed and distance
- Assume that cars can stop instantly
- Have difficulty discriminating the direction of sounds
- Cannot perceive complicated traffic situations
- Think that if they can see a vehicle, then the driver can see them
- Have a lack of well-developed "peripheral vision"
- Concentrate on what interests them the most at a particular time

In order to reduce the potential risks that our children face on the roads, they must be taught to appreciate their role, rights and responsibilities with respect to their safety on our roads and in other related situations. This resource is designed to help educators provide the students with the knowledge, skills and attitudes that will enable them to achieve the aforementioned objectives.

The Road Safety Program includes a series of learning activities and accompanying visuals and student worksheets. The learning activities reflect differentiated instruction (see *Success for All Learners*).

A Road Safety Scope and Sequence Matrix is provided. This matrix explains the "fit" between the Road Safety Learning Activities and relevant sections of the *Kindergarten to Senior 4 Physical Education / Health Education: Manitoba Curriculum Framework of Outcomes for Active Healthy Lifestyles*. There is a box in the bottom right-hand corner beside every specific Student Learning Outcome (SLO) that identifies the number of the learning activity or activities that addresses part or all of the SLO.

A sample Parent Letter is enclosed that identifies the specific content for the respective grade with suggestions for parental involvement to reinforce children's learning. Teachers may revise this Parent Letter before sending it home prior to the commencement of this program.

Teachers are to note that **not** all road safety content may be applicable to every community. Teachers are advised to use professional discretion in the selection of content. It is advisable to check what is taught of road safety in the previous grade.

Suggestions for Assessment are provided for every learning activity. There is a Teacher Road Safety Checklist provided at the end of each grade. This checklist can be used for ongoing observations and to determine student progress for assessment purposes. When planning their assessment, teachers are advised to refer to *Kindergarten to Senior 4 Physical Education/Health Education: Manitoba Curriculum Framework of Outcomes for Active Healthy Lifestyles, Appendix A: Assessment, Evaluation and Reporting*.

Road Safety is one aspect of the Safety General Student Learning Outcome #3 in the Framework document. The time allotted to teach Health Education in the classroom is limited. Curricular connections are provided for each learning activity. It is recommended that teachers use curricular connections in order to cover all the Road Safety Learning Activities. Teachers may wish to use some of the learning activities as Take-Home Activities for students to complete with their families. Road Safety is an ongoing concern and teachers are encouraged to review this topic with students on a seasonal basis.

This Road Safety Program provides teachers with a valuable, user-friendly resource that enhances the teaching of a topic that is important to daily living and active, healthy lifestyles.

**KINDERGARTEN
ROAD SAFETY
SCOPE and SEQUENCE**

LEGEND

Number(s) of Learning Activity or Activities that address part or all of SLOs.

Content/ Curricular Connections	SAFETY General Student Learning Outcome (GLO) #3 Specific Student Learning Outcomes (SLOs)	Complementary GLOs	
		Personal and Social Management #4 SLOs	Fitness Management #2 SLOs
<p>Knowledge: Strand B Safety of Self and Others</p> <p>1. Community Safety Awareness (Science and Social Studies)</p>	<p><input type="checkbox"/> K.3.K.B.1 Identify safety symbols, hazards and risks in everyday living (i.e. traffic, school bus ridership). Activities 1, 2, 3, 4, 7, 8, 9, 14, 16</p> <p><input type="checkbox"/> K.3.K.B.4 Recognize safety helpers in the community (e.g. parent/guardian, family member, babysitter, teacher, principal, police officer, bus driver, block parent, school patrols). Activities 10, 11, 16</p>		
<p>Skills: Strand A Application of Safety Practices...</p> <p>1. Physical Activity</p>	<p><input type="checkbox"/> S.3.K.A.1 Follow simple rules and routines for safe, active participation and use of equipment (e.g. follow instructions, stop for signal) in selected activities (e.g. walking home, crossing road, riding a bike). Activities 5, 6, 11, 12, 13, 14, 15, 16</p>	<p>Knowledge: Strand A Personal Development</p> <p>3. Decision-Making/Problem-Solving Process (ELA and Science) <input type="checkbox"/> K.4.K.A.3 Identify daily decisions and/or choices (e.g. what to wear, what is safe) and how choices are made for health and well-being. Activities 12, 15</p>	<p>Skills: Strand A Acquisition Fitness Management Skills...</p> <p>1. Active Participation a) general fitness activities <input type="checkbox"/> S.2.K.A.1a Participate in a wide variety of physical activities that contribute to skill/fitness development and enjoyment. Activities 6, 9, 15</p>

**KINDERGARTEN
ROAD SAFETY
SCOPE and SEQUENCE**

LEGEND

Number(s) of Learning Activity or Activities that address part or all of SLOs.

Content/ Curricular Connections	SAFETY General Student Learning Outcome (GLO) #3 Specific Student Learning Outcomes (SLOs)	Complementary GLOs	
		Personal & Social Management #4 SLOs	Fitness Management #2 SLOs
<p>Skills: Strand A Application of Safety Practices...</p> <p>1. Physical Activity (cont'd)</p>	<p><input type="checkbox"/> K.3.K.A.3 Distinguish between appropriate and inappropriate footwear for indoor and outdoor activities (e.g. shoes for outdoor physical activity). Activity 15</p>	<p>Skills: Strand A Acquisition P and SM Skills...</p> <p>2. Decision Making/Problem Solving (all subjects)</p> <p><input type="checkbox"/> S.4.K.A.2 Sort decisions and/or choices that are made daily, based on their positive or negative consequences (e.g. safe/unsafe). Activities 12, 13, 15</p>	
<p>Knowledge: Strand A Physical Activity Risk Management</p> <p>3. Dress/Footwear</p>			

**KINDERGARTEN
ROAD SAFETY
SCOPE and SEQUENCE**

LEGEND

Number(s) of Learning Activity or Activities that address part or all of SLOs.

Content/ Curricular Connections	SAFETY General Student Learning Outcome (GLO) #3 Specific Student Learning Outcomes (SLOs)	Complementary GLOs	
		Personal and Social Management #4 SLOs	Fitness Management #2 SLOs
<p>Knowledge: Strand B Safety of Self and Others 3. Prevention and Care of Injuries (Science)</p>	<p><input type="checkbox"/> K.3.K.B.3 Identify practices (i.e. follow rules and instructions, play in supervised areas, dress appropriately) to prevent injuries related to indoor and outdoor play (e.g. sunburn, frostbite, burns, bruises, bumps, cuts). Activities 12, 15</p>		
<p>1. Physical Activity Safety</p>	<p><input type="checkbox"/> K.3.K.A.1 Recognize safe and controlled movement while participating in physical activity (e.g. stop and start, enter and exit in a safe manner). Activity 9</p>		

Dear Parent/Guardian,

In the weeks ahead, the class will be studying **Road Safety**.
Students will focus on the following Road Safety areas:

- Traffic
- Pedestrian Safety
- Seat Belt Safety
- Community Safety Helpers

The learning activities actively involve the students in learning “safety rules” of the road. If you have any items at home that might improve our study of Road Safety (e.g. games, videos, magazine) that you would be willing to let us use, we would appreciate it.

We invite you to enhance your child’s learning by:

- modelling positive safety habits (e.g. wearing your seat belt, following road rules),
- doing the learning activities sent home with your child,
- discussing the importance of road safety.

Thank you for your support and involvement!

Sincerely,



ACTIVITY 1 What Is Traffic?

Prescribed Learning Outcomes:

Safety SLOs:

K.3.K.B.1 Identify safety symbols, hazards and risks in everyday life (i.e. traffic, school bus ridership).

Complementary SLOs:

Activity Outcomes:

Students will be able to:

- Describe what traffic and vehicles are.
 - Identify vehicles according to size.
 - Identify pictures of traffic.
-

Suggestions for Instruction:

- Brainstorm on flipchart paper what is meant by “traffic” (e.g. cars, trucks, motorcycles, buses, tractors, bicycles, trains).
 - Show Activity 1 Visuals A and B: *Traffic 1 and 2* to a small group or make an overhead for a class activity.
 - State that all of these things are vehicles because they are on the road and have wheels.
 - Ask children to name each vehicle, describe the sound it makes, and count the wheels.
 - Ask which vehicle is the smallest and which is the biggest.
 - Introduce Activity 1 Worksheet: *What is Traffic?*
 - Ask children to circle all traffic on the worksheet.
-

Suggestions for Assessment:

- Name traffic signs and ask students to identify the correct signs and state what they tell pedestrians to do.
-

Cross-Curricular Connections:

- English Language Arts (explore thoughts, ideas, feelings and experiences; comprehend and respond personally and critically to literary and media texts; enhance the clarity and artistry of communication)
 - Mathematics (shape and space)
 - Social Studies (being together)
-

Opportunities for Family/Community Involvement:

- Invite students to take their worksheets home and discuss traffic with their parents.

Traffic 1

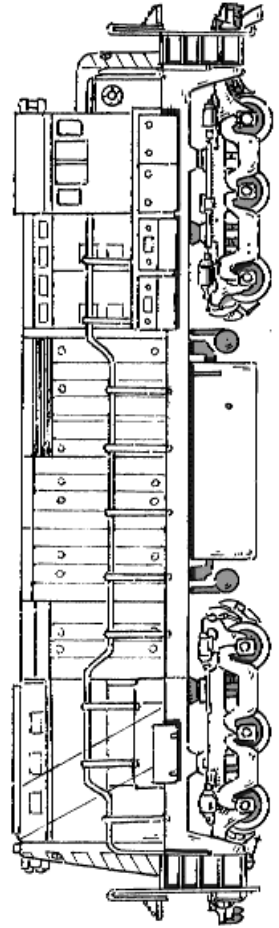
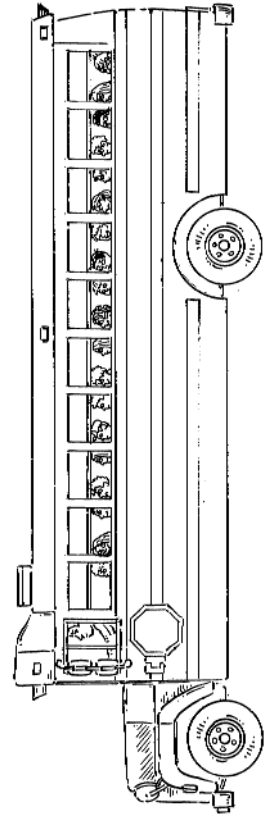
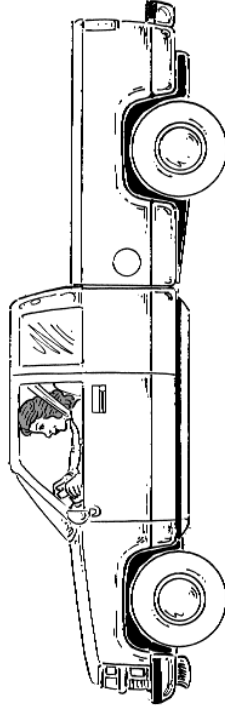
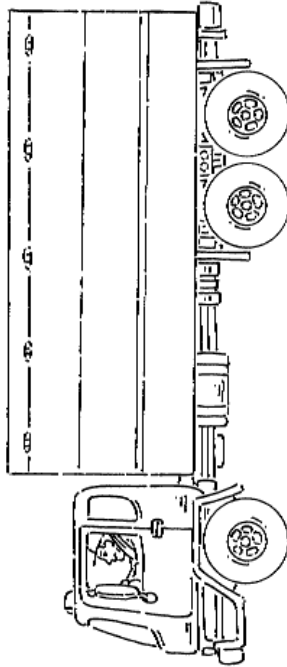
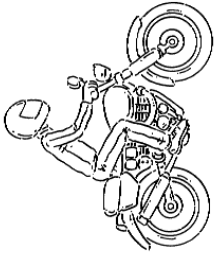
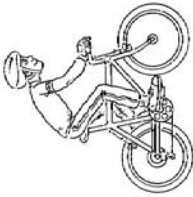
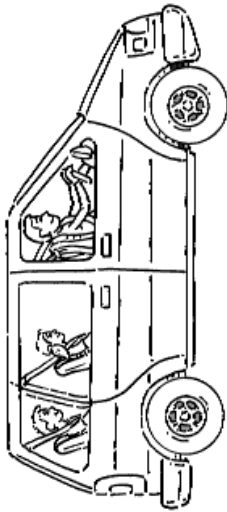

Car

Motorcycle

Bicycle

Minivan

Pick-up Truck

Truck

Train

School Bus

Traffic 2

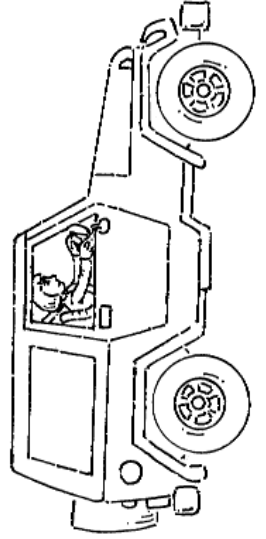
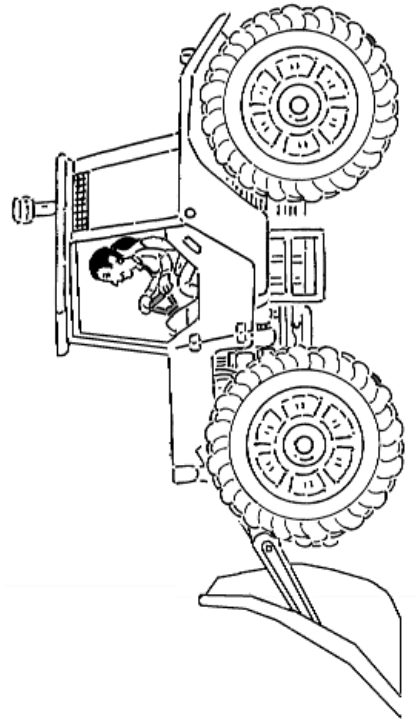
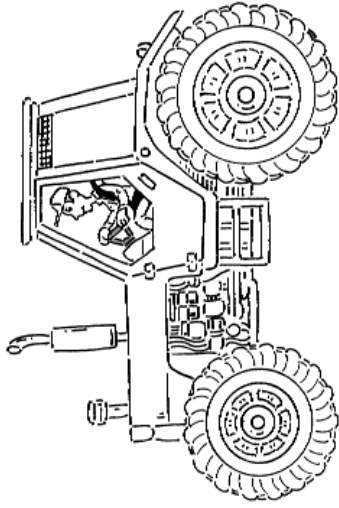
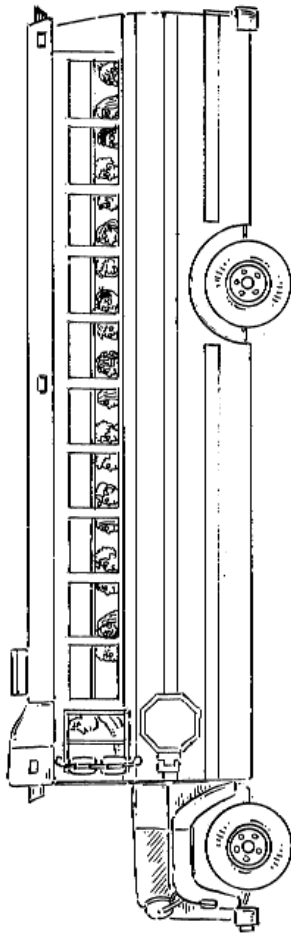
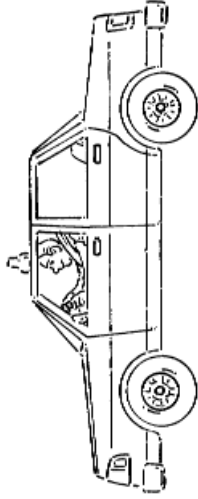
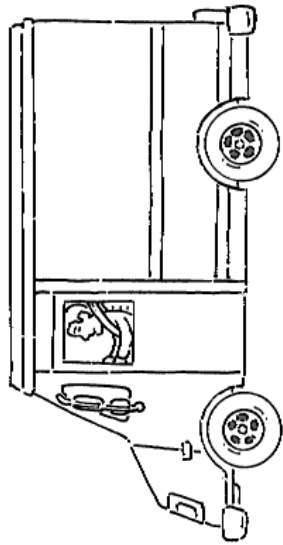

Taxi

Delivery Van

Tractor

School Bus

Jeep

Snow Plow

Instructions: Circle all traffic.

What is Traffic ?

Name: _____

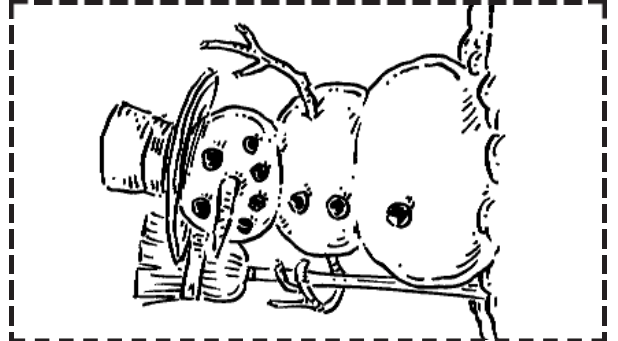
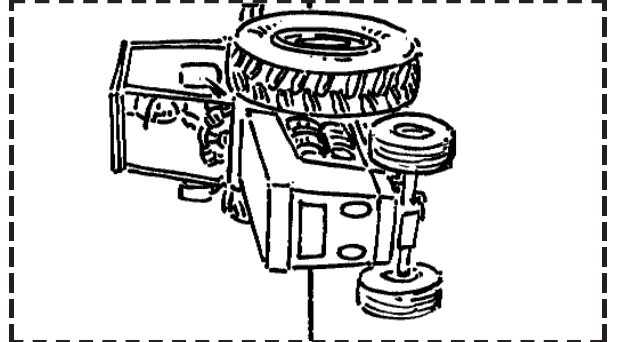
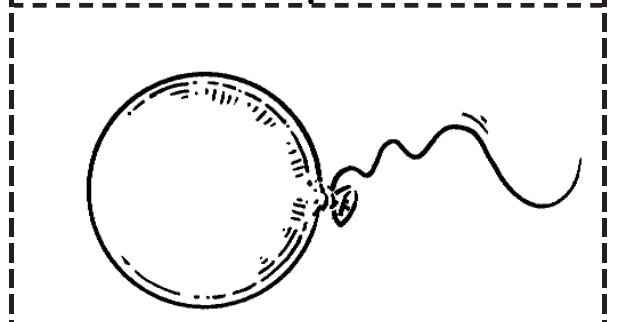
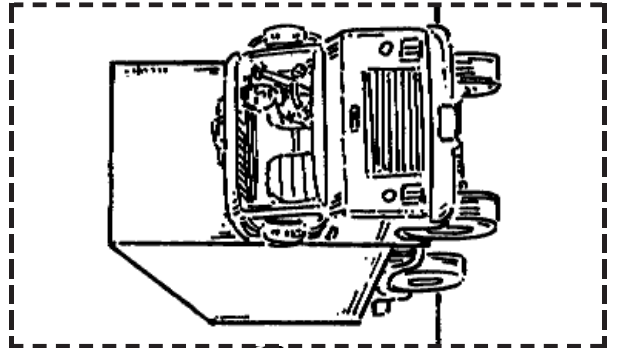
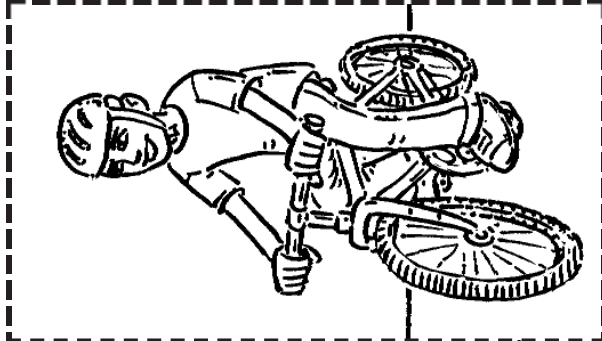
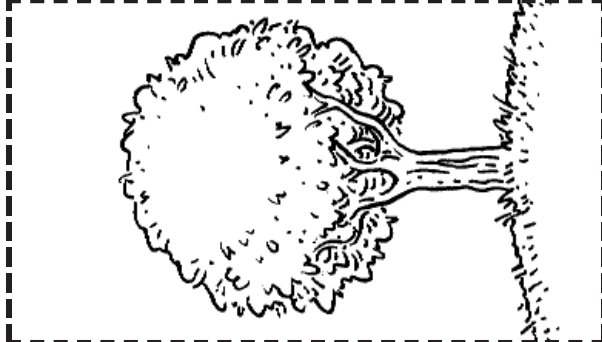
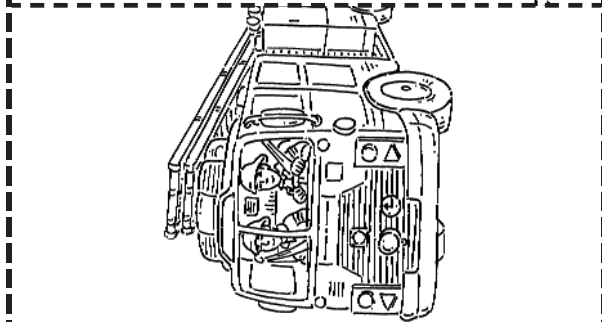
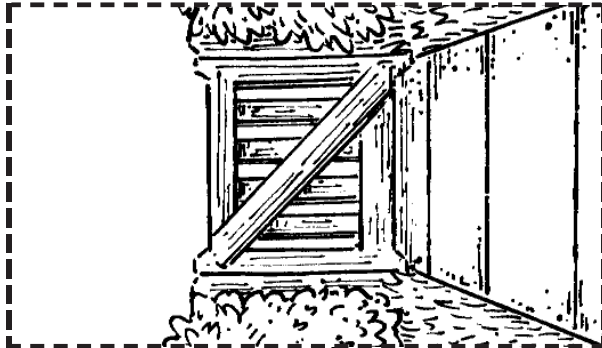
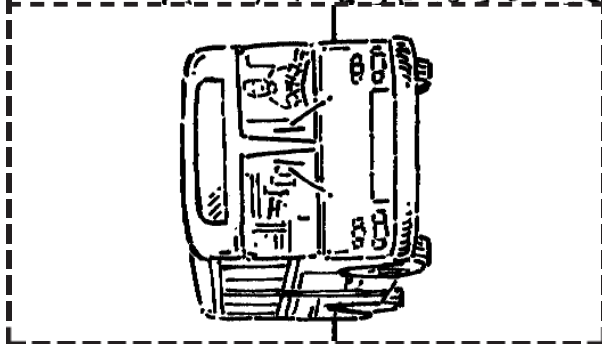

ACTIVITY 2 Road Safety Dot-to-Dot

Prescribed Learning Outcomes:

Safety SLOs:

K.3.K.B.1 Identify safety symbols, hazards and risks in everyday life.
(i.e. traffic, school bus ridership).

Complementary SLOs:

Activity Outcomes:

- Name 5 traffic signs (i.e. stop sign; traffic light; pedestrian crosswalk; pedestrian traffic light; railway crossing ahead).
 - State what each of the 5 traffic signs tells people to do.
 - Define what is meant by a pedestrian.
-

Suggestions for Instruction:

- State a pedestrian is a person who is walking.
 - Explain that pedestrians need to be safe while walking.
 - Show 5 coloured traffic signs, Activity 2 Visuals A-E, one at a time (e.g. stop sign; traffic light; pedestrian crossing; pedestrian traffic light; railway crossing).
 - Ask what each sign tells us to do.
 1. Stop sign – stop your feet;
 2. Traffic light – red means stop; yellow means look and listen for danger; green means go when it is safe;
 3. Pedestrian crosswalk – place where people may cross when it is safe and drivers are to stop so people may cross; stop, look both ways, listen, point your arm and cross when it is safe;
 4. Pedestrian traffic light – red hand means do not walk, flashing hand means get off the road, walking person means check for traffic, then cross the street when it is safe;
 5. Railway crossing ahead – stop, look and listen for trains.
 - State that all 5 signs are traffic signs that protect us around the road.
 - Introduce Activity 2 Worksheet: *Road safety dot-to-dot*.
 - Ask students to connect the dots in each of the 2 pictures and correctly colour.
-

Suggestions for Assessment:

- Name traffic signs and ask students to identify the correct signs and state what they tell pedestrians to do.

Cross-Curricular Connections:

- English Language Arts (explore thoughts, ideas, feelings and experiences; comprehend and respond personally and critically to literary and media texts)
 - Mathematics (number)
 - Science (colours)
-

Opportunities for Family/Community Involvement:

- Invite students to take their parents on a safety walk to spot the 5 traffic signs.



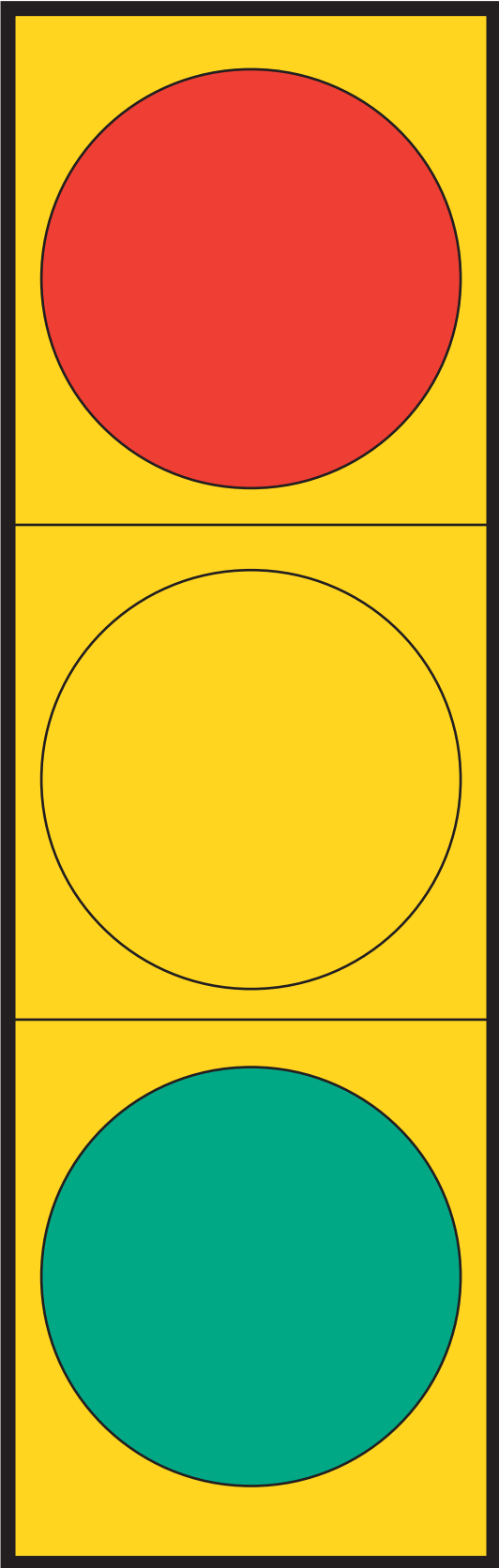



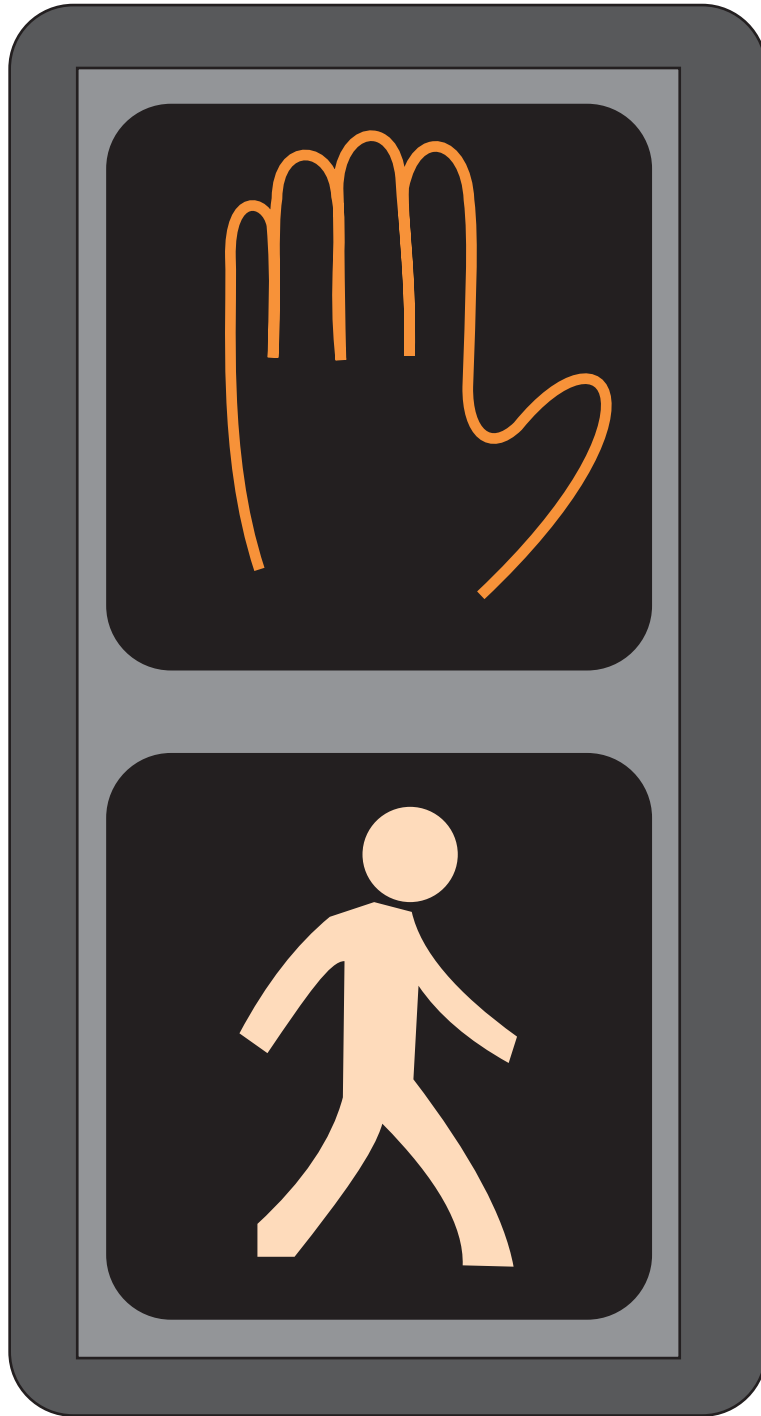

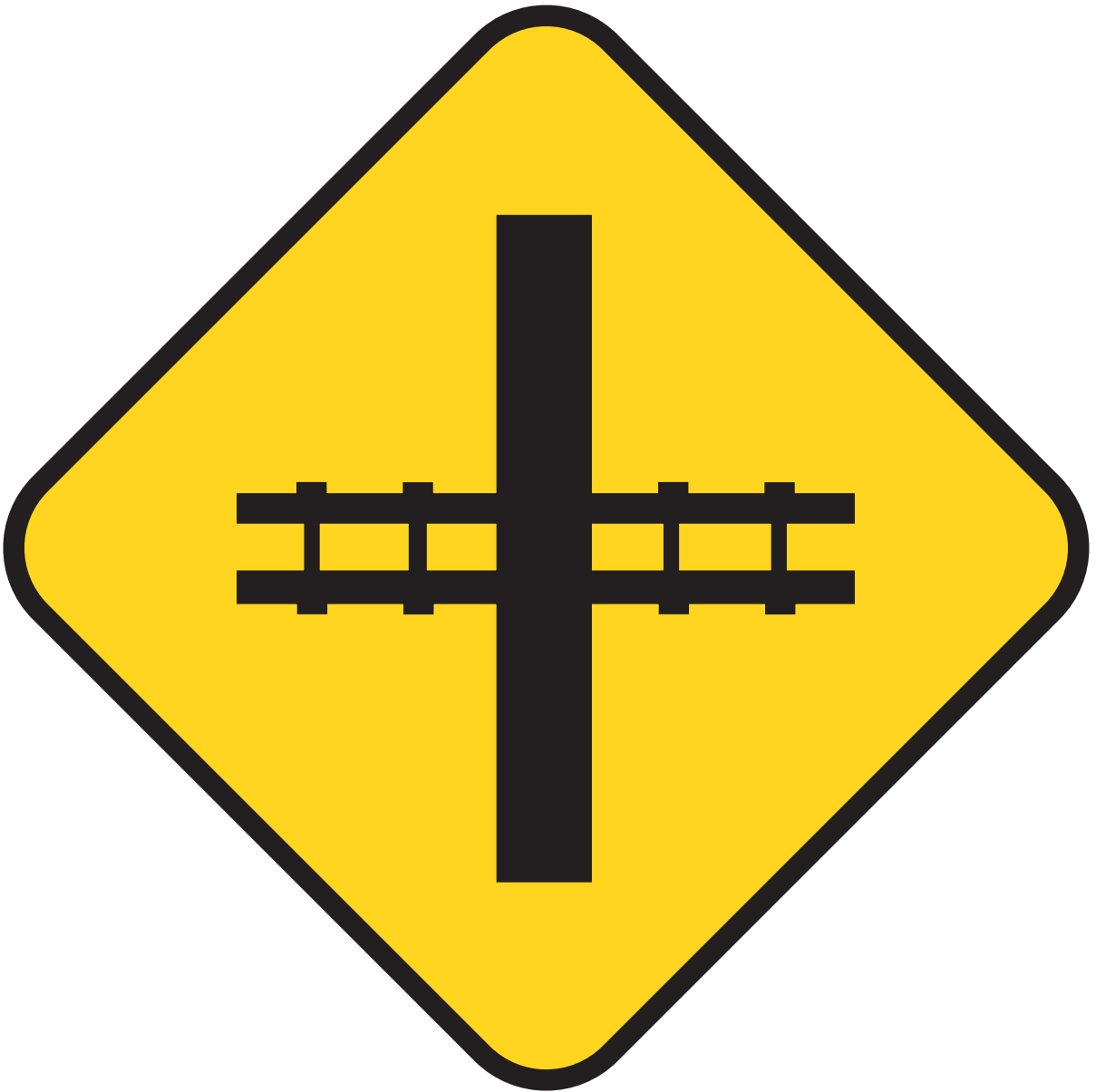

Instructions: Connect the dots.

Road safety dot-to-dot

Name: _____

K.3.K.B.1

20

30

10

80

STOP

40

50

70

60

5

30

10

15

25

20

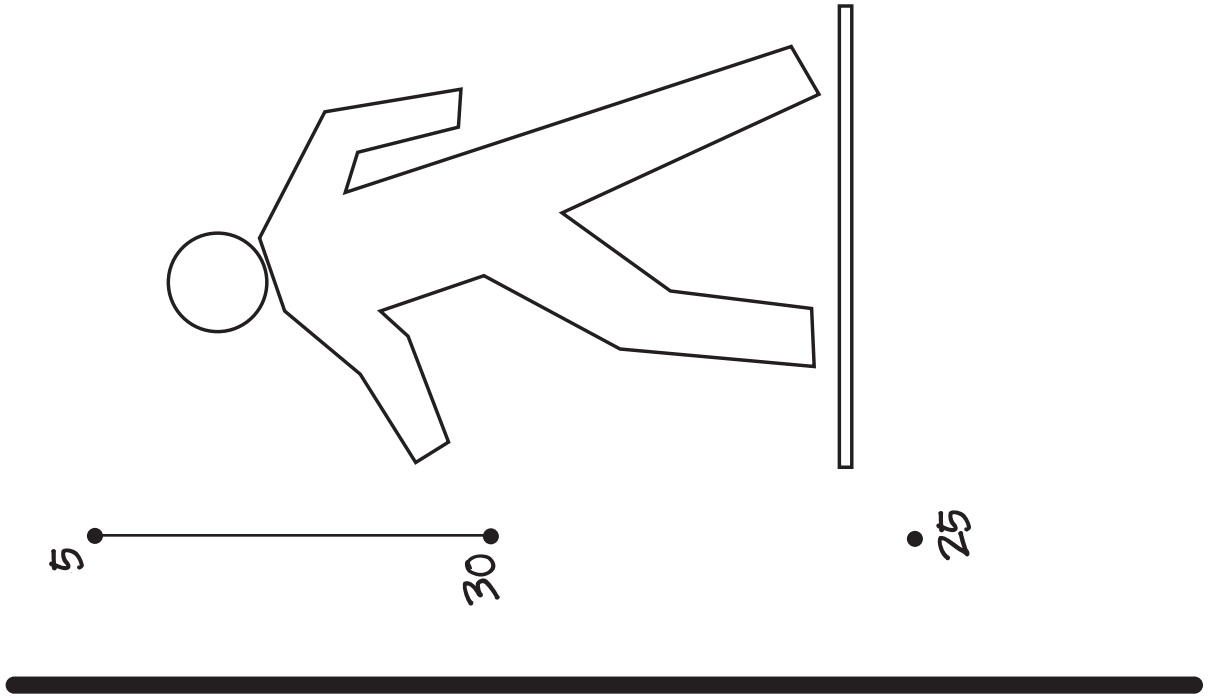

K-21

ACTIVITY 3 Traffic Light

Prescribed Learning Outcomes:

Safety SLOs:

K.3.K.B.1 Identify safety symbols, hazards and risks in everyday life (i.e. traffic, school bus ridership).

Complementary SLOs:

Activity Outcomes:

Students will be able to:

- Name the colours seen on the traffic light.
 - State what each colour on the traffic light tells people.
-

Suggestions for Instruction:

- Show the coloured traffic light from the previous activity.
 - Ask students to name the first colour seen at the top of a traffic light. (Answer: Red)
 - Ask students what the red light tells us. (Answer: Stop)
 - Ask students to name the second colour seen in the middle of a traffic light. (Answer: Amber/Yellow)
 - Ask students what the amber/yellow light tells us. (Answer: Wait)
 - Ask students to name the third colour seen at the bottom of a traffic light. (Answer: Green)
 - Ask students what the green light tells us. (Answer: Go)
 - Introduce Activity 3 Worksheet: *Traffic light*.
 - Ask students to colour each of the three colours on the traffic light.
-

Suggestions for Assessment:

- Ask students to name the three colours seen on a traffic light and what each light tells people.
-

Cross-Curricular Connections:

- English Language Arts (explore thoughts, ideas, feelings and experiences; comprehend and respond personally and critically to literary and media texts)
 - Mathematics (number)
 - Science (colours)
 - Visual Arts
-

Opportunities for Family/Community Involvement:

- Invite students to take their worksheets home and name for their parents the colours on a traffic light and what each colour tells people.

Instructions: Colour.

Traffic light

Name: _____

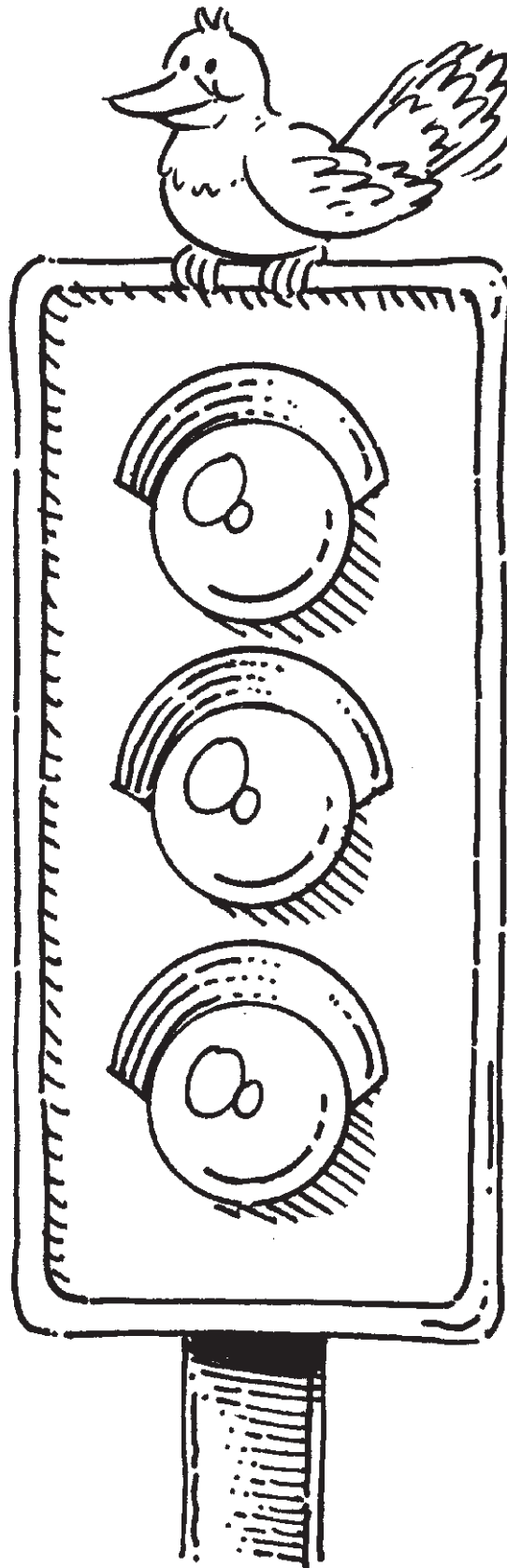

ACTIVITY 4 Traffic Signs – Song 1

Prescribed Learning Outcomes:

Safety SLOs:

K.3.K.B.1 Identify safety symbols, hazards and risks in everyday life (i.e. traffic, school bus ridership).

Complementary SLOs:

Activity Outcomes:

Students will be able to:

- Review the traffic signs.
-

Suggestions for Instruction:

- Sing the safety song “Where Is Traffic Sign?” to the tune of “Are You Sleeping?/Where Is Thumbkin?”
 - Display the traffic signs as they are identified in the song.
-

Suggestions for Assessment:

- Display a traffic sign while the song is sung.
 - Ask students to raise their hands if it is the correct sign.
-

Cross-Curricular Connections:

- Music
 - English Language Arts (explore thoughts, ideas, feelings and experiences; celebrate and build community)
-

Opportunities for Family/Community Involvement:

- Invite students to take the song home for their families to sing together.

WHERE IS TRAFFIC SIGN?

(Sung to the tune “Are You Sleeping?/Where Is Thumbkin?”)



Where is stop sign?
Where is stop sign?
Here I am! (Show stop sign)
Here I am!
Red is my colour.
A very trusty fellow.
Stop right there!
Stop right there!

Where is traffic light?
Where is traffic light?
Here I am! (Show traffic light)
Here I am!
Red tells us stop!!
Yellow says wait!
Green we go!
The traffic light will know!

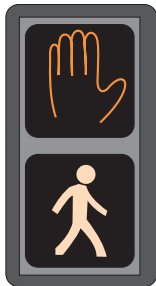
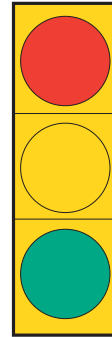

Where is crosswalk sign?
Where is crosswalk sign?
Here I am! (Show pedestrian crossing sign)
Here I am!
My colour is black and white.
Cars will keep me in their sight.
Walk where it's safe!
Walk where it's safe!

- Debbie Kaatz

ACTIVITY 5 Do You Know The Road Safety Rules? _____

Prescribed Learning Outcomes:

Safety SLOs:

S.3.K.A.1 Follow simple rules and routines for safe, active participation and use of equipment in selected activities.

Complementary SLOs:

Activity Outcomes:

Students will be able to:

- State the pedestrian safety rules.
 - State the vehicle passenger safety rules.
-

Suggestions for Instruction:

- Using a show of hands, ask students the following questions:
 1. Do you hold your parents' hands when crossing the road?
 2. Do you stop behind the curb before you cross the road?
 3. Do you look and listen for traffic?
 4. Do you look for traffic before crossing driveways and back lanes?
 5. Do you always wear a seat belt?
- Review all road safety rules:
 1. Cross at intersections and crosswalks (e.g. where there are school patrols, traffic lights).
Cross where it is safe (rural).
 2. Stop behind the curb or roadside.
 3. Look and listen for traffic on the road.
 4. Hold hands with an adult, sibling or friend when crossing the road.
 5. Look both ways for traffic before crossing roads, driveways and back lanes.
 6. Point your arm to cross the road.
 7. Cross when it is safe.
 8. Play in safe places.
 9. Always wear a seat belt. Listen for the click!
- Show Activity 5 Visuals A and B: *Do you know the road safety rules?* to a small group or make an overhead for a class activity.
- Ask students to identify the safety "Dos" (positive safety behaviours).
(Answers in Activity 5 Visual A:
 - a) children are playing in playground;
 - b) adult and child are crossing at crosswalk;
 - c) adult and child are stopped behind the curb;
 - d) adult and child are holding hands to cross road safely;
 - e) adult is pointing arm to cross road;
 - f) driver of car is wearing a seat belt.)

(Answers in Activity 5 Visual B:

- a) older sibling and child are stopped behind the roadside;
 - b) older sibling and child are holding hands to cross the road;
 - c) driver and passengers of car are wearing seat belts;
 - d) children are playing ball in a field.)
-

Suggestions for Assessment:

- Ask students to demonstrate crossing the road safely through simulations.
 - Ask students to name the safety rule to follow when riding in a motor vehicle.
 - Use the Teacher Road Safety Checklist to assess students' road safety knowledge.
(See Assessment Tool.)
-

Cross-Curricular Connections:

- English Language Arts (explore thoughts, ideas, feelings and experiences)
 - Social Studies (being together)
-

Opportunities for Family/Community Involvement:

- Send a copy of the road safety rules home for students to discuss with their families.

Do you know the road safety rules ?

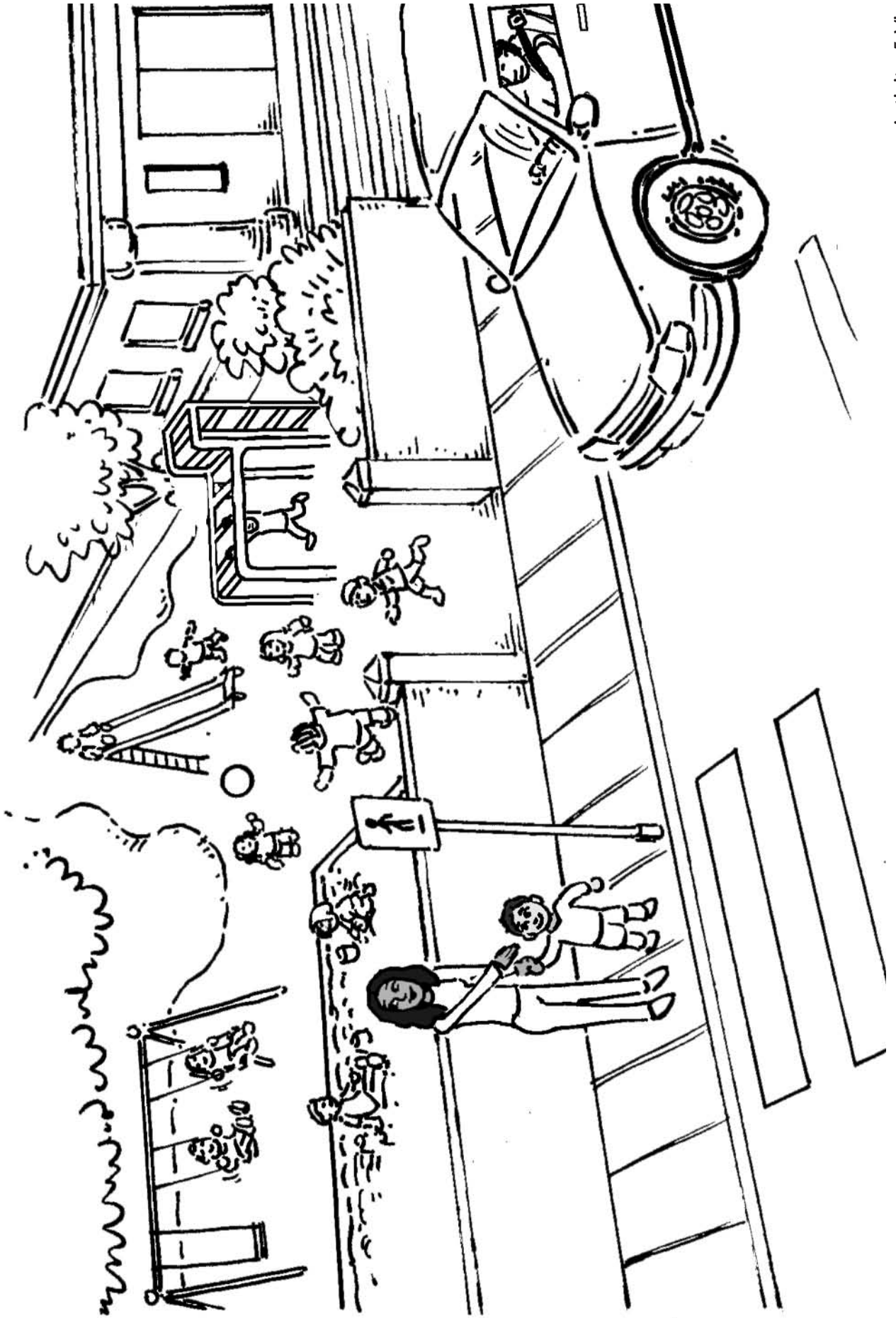

Do you know the road safety rules ?

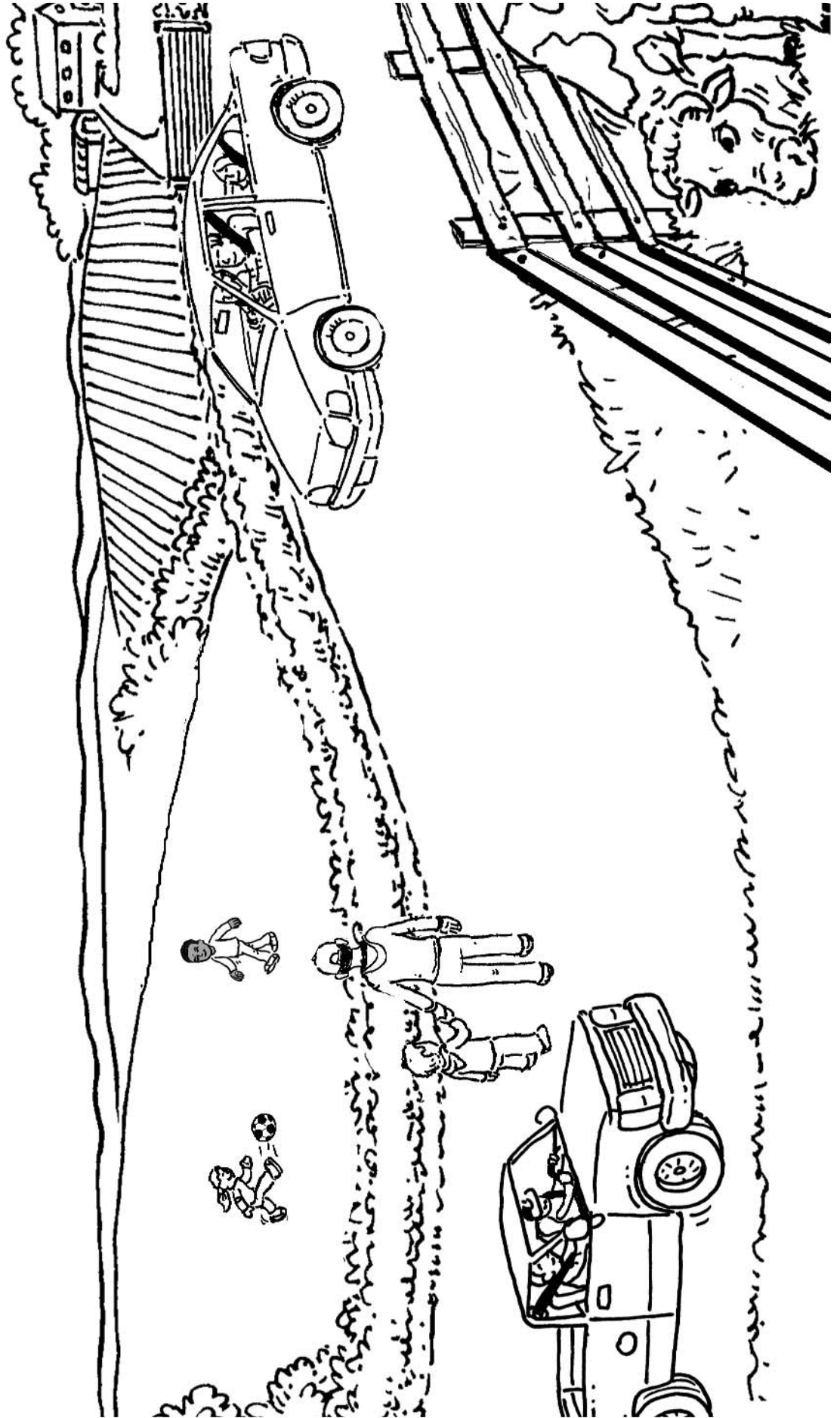

ACTIVITY 6 Crossing Safely – Song 2

Prescribed Learning Outcomes:

Safety SLOs:

S.3.K.A.1 Follow simple rules and routines for safe, active participation and use of equipment in selected activities.

Complementary SLOs:

S.2.K.A.1a Participate in a wide variety of physical activities that contribute to skill/fitness development and enjoyment.

Activity Outcomes:

Students will be able to:

- Perform the complete sequence for crossing the road safely.
 - Participate in a simple action song.
-

Suggestions for Instruction:

- Sing the safety song “Crossing The Road Safely” to the tune “Row, Row, Row Your Boat”.
 - Perform the actions suggested at the appropriate time in the song.
 - Show Activity 6 Visual: *Stop, look, listen* to a small group or make an overhead for a class activity.
 - Reinforce each action in the crossing the road safely sequence.
-

Suggestions for Assessment:

- Ask students to demonstrate the correct way to cross the road safely through simulations.
 - Use the Teacher Road Safety Checklist to assess students’ road safety skills during the simulations. (See Assessment Tool.)
-

Cross-Curricular Connections:

- Music
 - English Language Arts (explore thoughts, ideas, feelings and experiences; celebrate and build community)
-

Opportunities for Family/Community Involvement:

- Invite students to take the song home for their families to sing together.

CROSSING THE ROAD SAFELY

(Sung to the tune "Row, Row, Row Your Boat")

Stop! Stop! Stop your feet,
(Action: walking motion then full halt)

Right behind the curb,
(Action: stop behind a line that represents the curb)

Look and listen and point your arm
(Action: point to eyes, touch ears, place arm out in front)

Before you leave the curb!

- Dawn White

stop

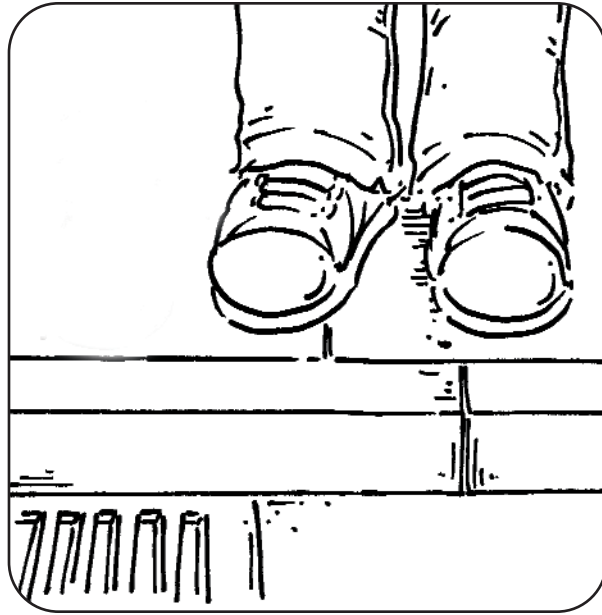

look

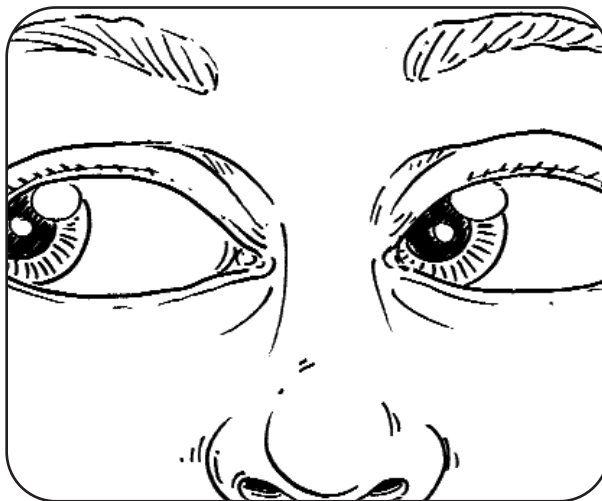

listen

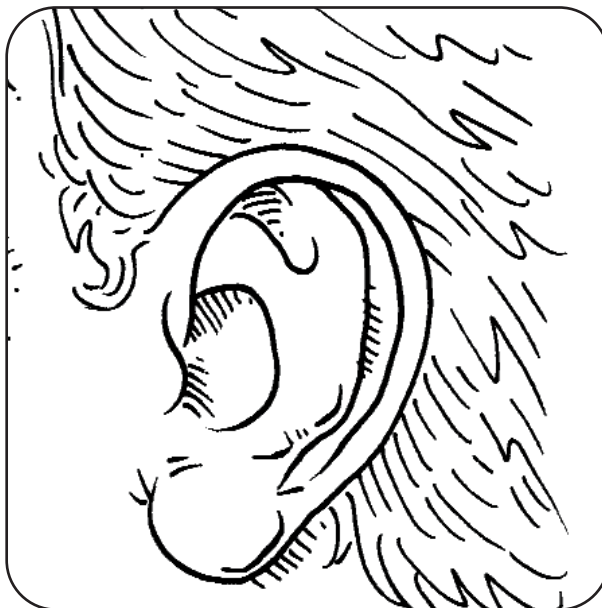

ACTIVITY 7 Where's The Road Danger?

Prescribed Learning Outcomes:

Safety SLOs:

K.3.K.B.1 Identify safety symbols, hazards and risks in everyday life (i.e. traffic, school bus ridership).

Complementary SLOs:

Activity Outcomes:

Students will be able to:

- Identify some dangers on the road.
 - State why these things are dangers.
-

Suggestions for Instruction:

- Brainstorm what is meant by danger. (Answer: something that might hurt/harm you)
 - Ask the students to give examples of some road dangers they must watch for on their way to and from school.
 - Discuss road dangers students must watch for when they are playing.
 - Show Activity 7 Visual: *Where's the road danger?* to a small group or make an overhead for a class activity.
 - Ask students to name the road dangers in illustration 1.
(Answers:
 - a) boy runs to ice cream truck;
 - b) ball rolls onto road and boy runs after it;
 - c) boy is not holding parent's hand;
 - d) boy is not stopping behind the curb;
 - e) boy is not looking and listening for traffic.)
 - Ask students why these things are road dangers and what might happen.
 - Ask students to name the road dangers in illustration 2.
(Answers:
 - a) child playing on snow bank near road;
 - b) snow plow;
 - c) child pulling toboggan on the road.)
 - Ask students why these things are road dangers and what might happen.
-

Suggestions for Assessment:

- Ask students to name some dangers to watch for on the road and explain why these things are dangers.
- Use the Teacher Road Safety Checklist to assess students' road safety knowledge. (See Assessment Tool.)

Cross-Curricular Connections:

- Social Studies (being together)
 - English Language Arts (enhance the clarity and artistry of communication)
-

Opportunities for Family/Community Involvement:

- Invite students to take their parents on a safety walk and name the road dangers seen.

Where's the road danger?

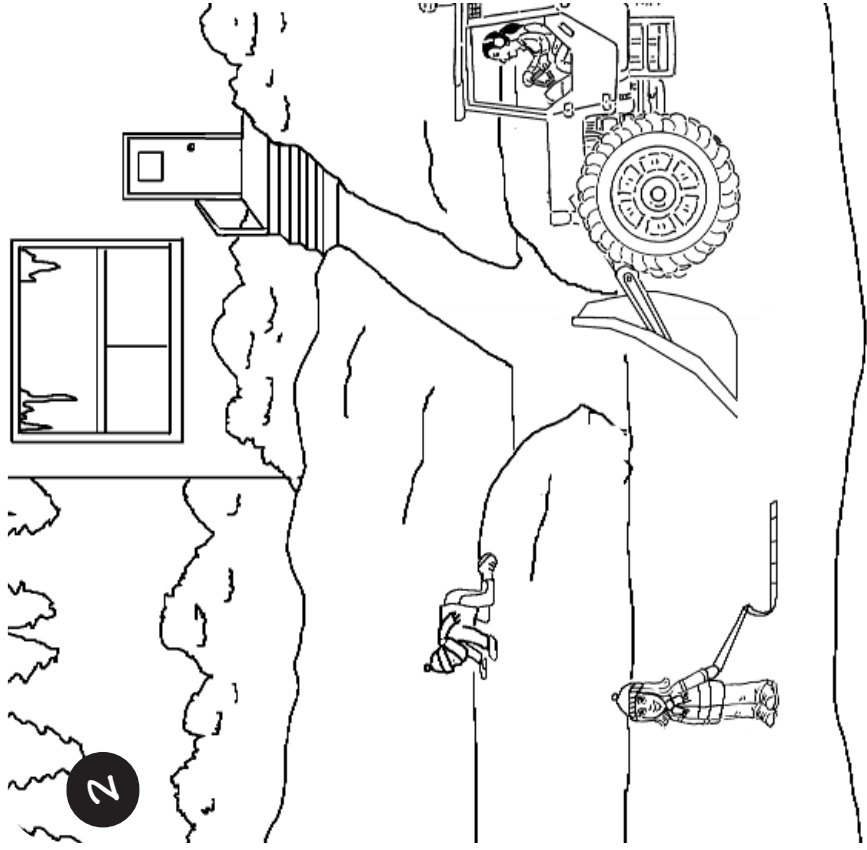

ACTIVITY 8 / Spy The Road Danger

Prescribed Learning Outcomes:

Safety SLOs:

K.3.K.B.1 Identify safety symbols, hazards and risks in everyday life (i.e. traffic, school bus ridership).

Complementary SLOs:

Activity Outcomes:

Students will be able to:

- Identify some dangers on the road.
 - State why these things are dangers.
-

Suggestions for Instruction:

- Prepare Activity 8 Worksheet: *I spy the road danger* as an overhead.
 - Review what a road danger is. (Answer: something that might hurt or harm you)
 - Brainstorm all the road dangers spied on the overhead worksheet.
 - Introduce Activity 8 Worksheet: *I spy the road danger*.
 - Ask students to place an X or suitable mark on all the road dangers in the picture.
 - Discuss the students' answers about why each is a road danger.
(Answers:
 - a) cyclist is not wearing a helmet;
 - b) truck driver is not wearing a seat belt;
 - c) a child is chasing a ball onto the road;
 - d) a child is in front of the tractor and near an oncoming truck;
 - e) a child is playing near the curb.)
-

Suggestions for Assessment:

- Have students state why they marked things as road dangers on their worksheets.
-

Cross-Curricular Connections:

- Social Studies (being together)
 - English Language Arts (enhance the clarity and artistry of communication)
-

Opportunities for Family/Community Involvement:

- Invite students to take their parents on a safety walk and name the road dangers seen.

I spy the road danger

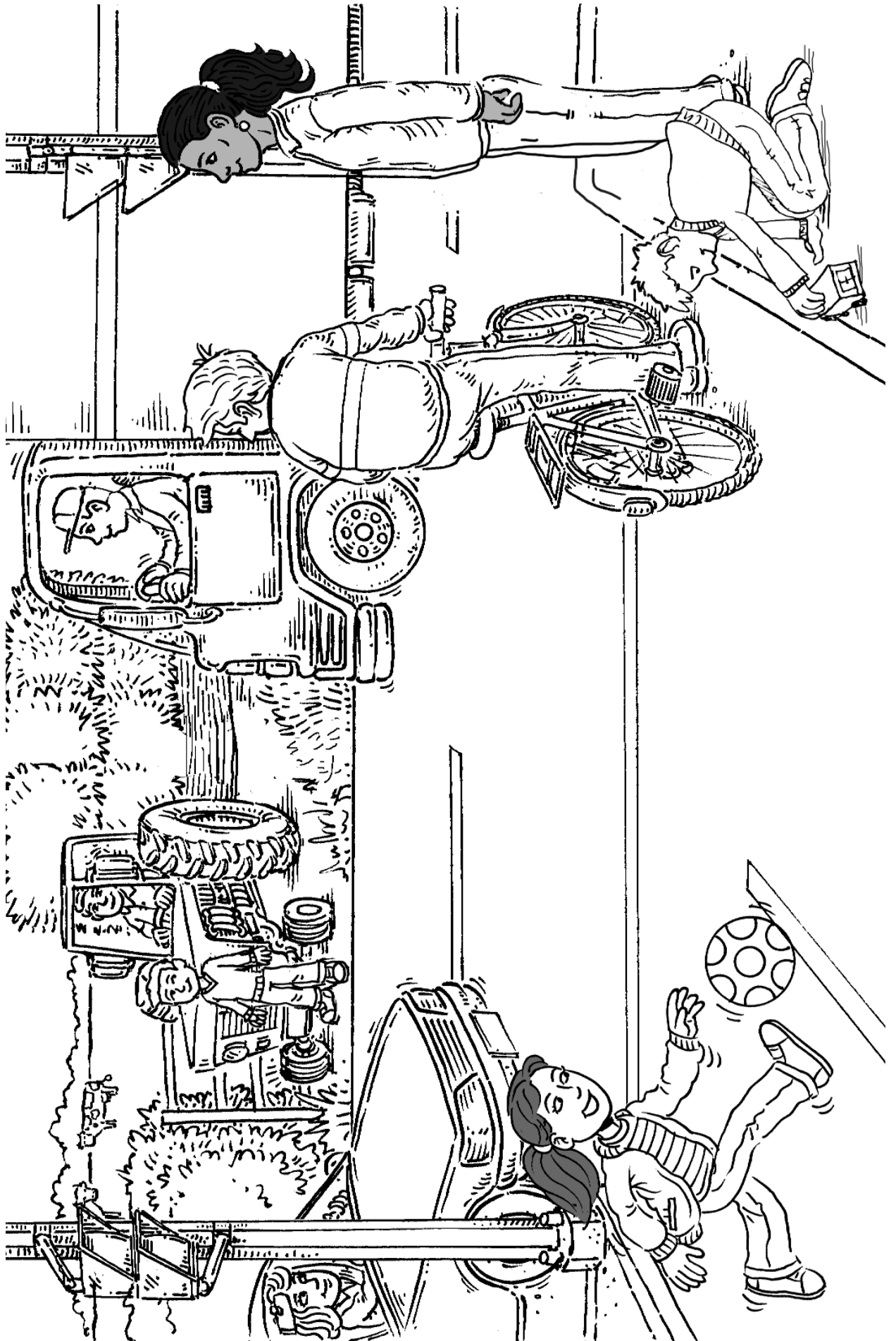

ACTIVITY 9 Red Light, Green Light

Prescribed Learning Outcomes:

Safety SLOs:

K.3.K.B.1 Identify safety symbols, hazards and risks in everyday life (i.e. traffic, school bus ridership).

K.3.K.A.1 Recognize safe and controlled movement while participating in physical activity (e.g. stop and start, enter and exit in a safe manner).

Complementary SLOs:

S.2.K.A.1a Participate in a wide variety of physical activities that contribute to skill/fitness development and enjoyment.

Activity Outcomes:

Students will be able to:

- Perform the game safely.
 - Follow instructions for red light and green light.
-

Suggestions for Instruction:

- One student is chosen to be the “traffic light” and stands at the front with her/his back to the class.
 - Mark a line on the floor that the students must cross to become the new “traffic light”.
 - When the “traffic light” says “green light” all students creep forward to try and cross the line.
 - The “light” shouts “red light” and turns around.
 - If anyone is seen moving, s/he goes to the back of the room and starts again.
 - The first student to cross the line becomes the new “traffic light”.
-

Suggestions for Assessment:

- Have students describe how to act safely while participating in a physical activity (e.g. stop and start, watch they do not collide into others).
-

Cross-Curricular Connections:

- Physical Education/Health Education (movement; fitness management)
-

Opportunities for Family/Community Involvement:

- Invite students to play the game at home with their friends and/or families.

ACTIVITY 10 Who Can Help Us? Riddles

Prescribed Learning Outcomes:

Safety SLOs:

K.3.K.B.4 Recognize safety helpers in the community (e.g. parent/guardian, babysitter, teacher, ambulance driver, police, RCMP).

Complementary SLOs:

Activity Outcomes:

Students will be able to:

- Describe what a safety helper does.
 - Identify the types of safety helpers in the community.
 - Name the safety helper by the job done.
-

Suggestions for Instruction:

- Ask students if they help their families with jobs around the house.
 - State that helpers are people who “help” or “lend a hand” to those in need.
 - Brainstorm for ways that students help at home.
 - State that a safety helper is a person who “helps” to keep people safe.
 - Brainstorm on flipchart paper the types of safety helpers in the community (e.g. parent, babysitter, teacher, bus driver, school patrol, Block Parent, police officer, ambulance driver, RCMP).
 - Read each of the 3 riddles *Who Can Help Us? Community Safety Helper Riddles* and ask students to guess who the community safety helper is.
 - Once students have guessed whom the helper might be, show the matching Activity 10 Visual A, B or C; *Community Safety Helper* that is the correct answer to each riddle. (Answers: babysitter, parent, teacher.)
 - Ask students to watch for these safety helpers in their neighbourhood.
-

Suggestions for Assessment:

- Ask students to choose one community safety helper and draw a picture of this safety helper.
-

Cross-Curricular Connections:

- Social Studies (being together)
 - English Language Arts (enhance the clarity and artistry of communication; comprehend and respond personally and critically to literary and media texts)
-

Opportunities for Family/Community Involvement:

- Invite a community safety helper to class to discuss her/his job.

WHO CAN HELP US?
COMMUNITY SAFETY HELPER RIDDLES

RIDDLE 1: I take care of children
All sizes and ages.
We play games, sing songs
Read books with many pages.
Who am I?
Answer: Babysitter (Activity 10 Visual A)

RIDDLE 2: I am one of your family,
I want what's best for you.
Keeping you healthy and safe
Is important for me to do.
Who am I?
Answer: Parent (Activity 10 Visual B)

RIDDLE 3: I help you to read
And teach things that are new.
We draw, paint and count.
One and one are two.
Who am I?
Answer: Teacher (Activity 10 Visual C)

- Debbie Kaatz

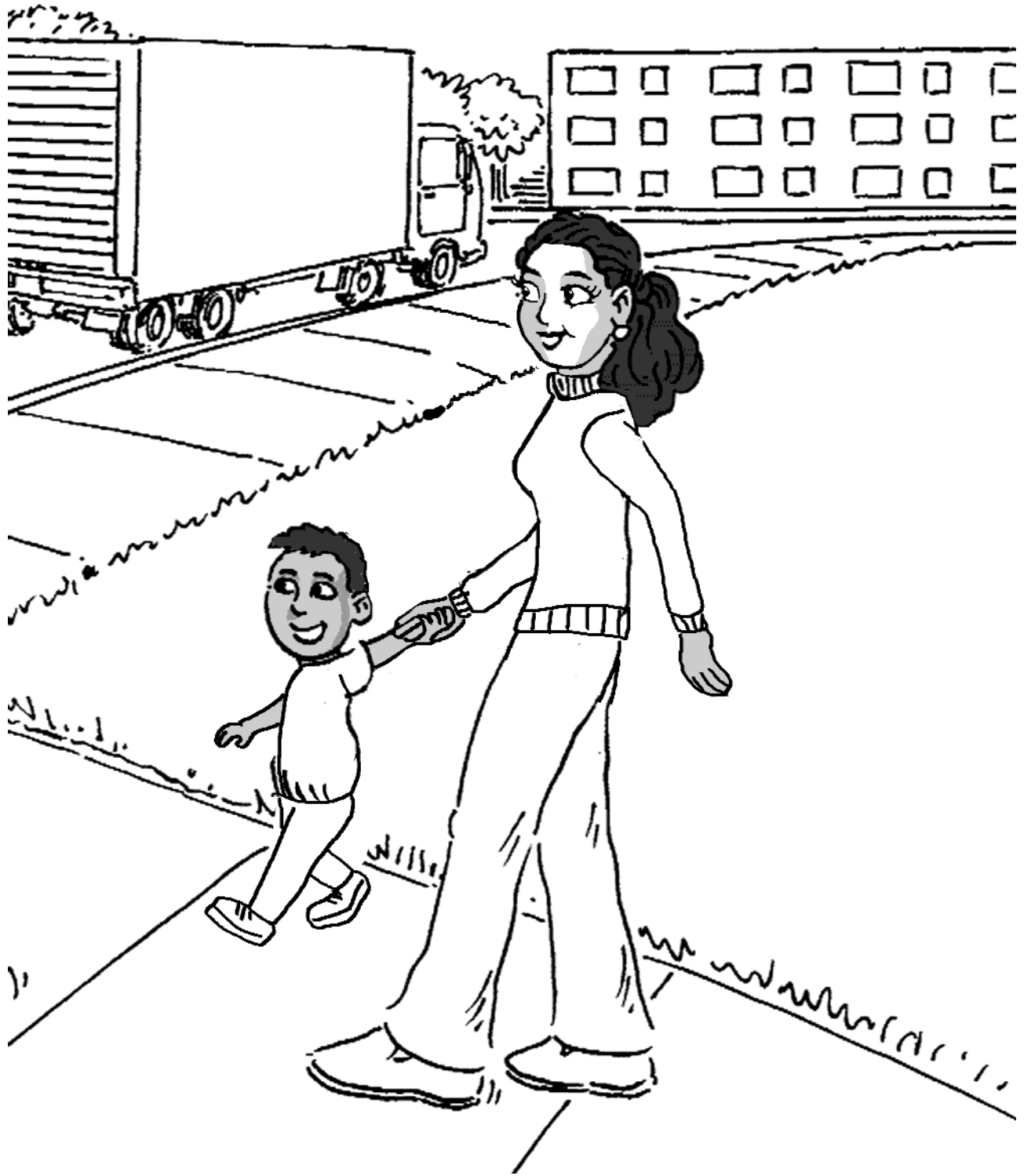

Community safety helper



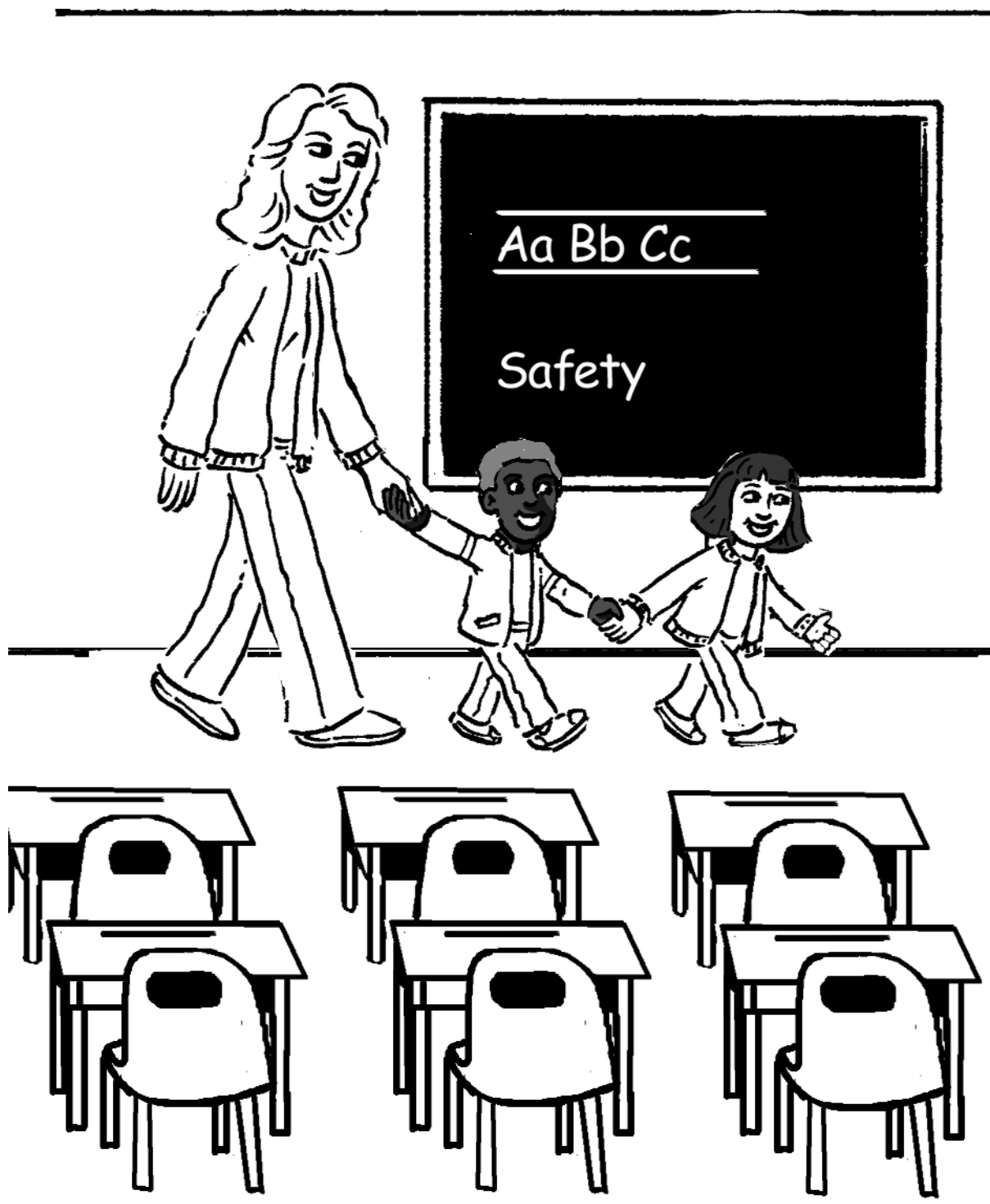

ACTIVITY 11 Safety Helpers – Song 3

Prescribed Learning Outcomes:

Safety SLOs:

K.3.K.B.4 Recognize safety helpers in the community (e.g. parent, adult, teacher, babysitter).

S.3.K.A.1 Follow simple rules and routines for safe, active participation and use of equipment in selected activities.

Complementary SLOs:

Activity Outcomes:

Students will be able to:

- Review the types of safety helpers in the community.
 - State pedestrian road safety rules.
-

Suggestions for Instruction:

- Sing the safety song “Safety Helpers” to the tune “London Bridge”.
 - Display the pictures of the community safety helpers (from the previous learning activity) as they are identified in the song.
-

Suggestions for Assessment:

- Ask students to name 2 safety helpers in the community.
 - Ask students to demonstrate how to cross the road safely.
-

Cross-Curricular Connections:

- Music
 - Social Studies (being together)
 - English Language Arts (explore thoughts, ideas, feelings and experience; celebrate and build community)
-

Opportunities for Family/Community Involvement:

- Invite students to take the song home for their families to sing together.

SAFETY HELPERS

(Sung to the tune of "London Bridge")

First we stop at the curb, at the curb, at the curb,
First we stop at the curb, stop, look and listen.

Then we hold an adult's hand, adult's hand, adult's hand,
Then we hold an adult's hand, stop, look and listen.

Parents help us cross the road, cross the road, cross the road,
Parents help us cross the road, hold their hands.

Babysitters help us too, help us too, help us too,
Babysitters help us too, watch for traffic.

Cross while looking left and right, left and right, left and right,
Cross while looking left and right, point your arm.

- Debbie Kaatz and Dawn White

ACTIVITY 12 Safety Maze

Prescribed Learning Outcomes:

Safety SLOs:

- S.3.K.A.1** Follow simple rules and routines for safe, active participation and use of equipment in selected activities.
- K.3.K.B.3** Identify practices (i.e. follow rules, play in supervised areas, dress appropriately) to prevent injuries related to indoor and outdoor play.

Complementary SLOs:

- K.4.K.A.3** Identify daily decisions and/or choices (e.g. what is safe) and how choices are made for health and well-being.
 - S.4.K.A.2** Sort decisions and/or choices that are made daily, based on their positive or negative consequences.
-

Activity Outcomes:

Students will be able to:

- Name safe and unsafe places to play.
 - Select safe places to play.
 - Identify the consequences of playing in safe and unsafe places.
-

Suggestions for Instruction:

- Ask students to name:
 1. safe places to play (e.g. playground, fenced park, my yard).
Why? (e.g. no traffic)
 2. unsafe (not safe) places to play (e.g. parking lot, on the road).
Why? (e.g. might be hit by a car; run over)
 - Introduce Activity 12 Worksheet A: *Summer safety maze*.
 - Ask students to use a pencil to find a way to a safe place to play for the adult and child in the picture.
 - Introduce Activity 12 Worksheet B: *Winter safety maze*.
 - Ask students to use a pencil to find a way to a safe place to play for the adult and child in the picture.
-

Suggestions for Assessment:

- Ask students to name safe places to play and say why these places are safe.
-

Cross-Curricular Connections:

- Social Studies (being together)
-

Opportunities for Family/Community Involvement:

- Invite students to talk to their parents about safe places to play in their neighbourhoods.

Summer safety maze

Instructions: Find a way to a safe place to play.

Name: _____

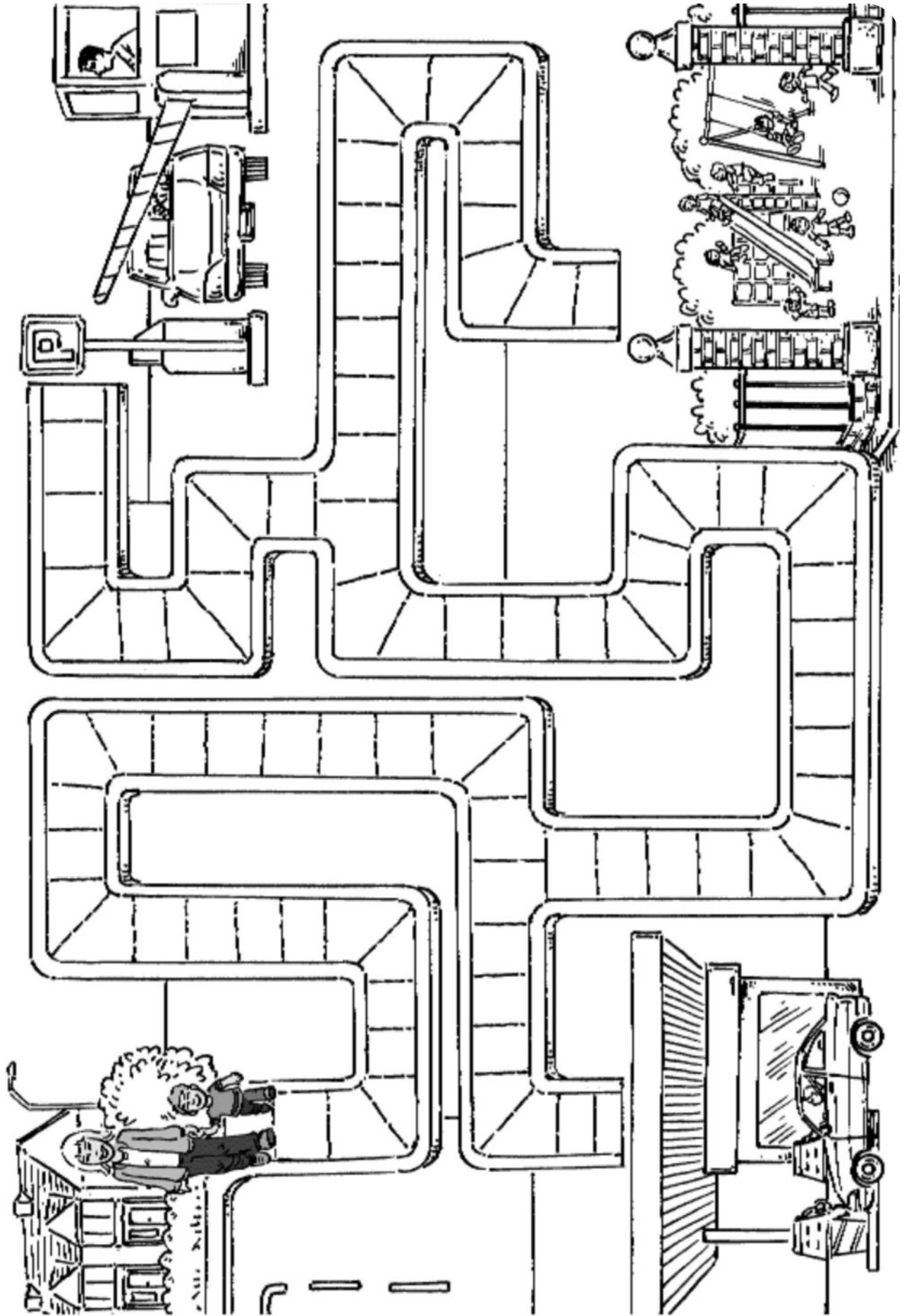

S.3.K.A.1
K.3.K.B.3

Instructions: Find a way to a safe place to play.

Winter safety maze

Name: _____

S.3.K.A.1
K.3.K.B.3

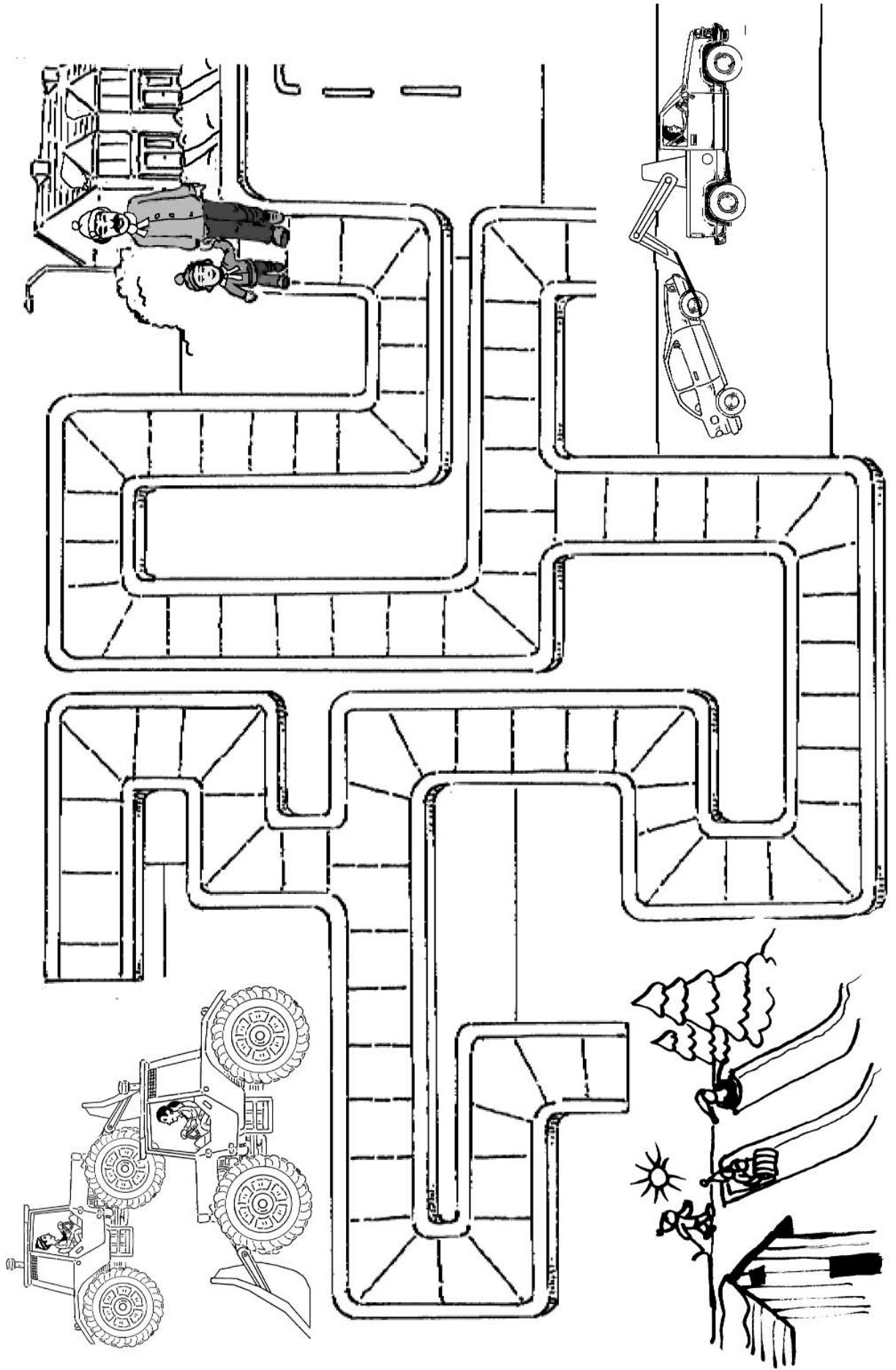

ACTIVITY 13 Safe Places

Prescribed Learning Outcomes:

Safety SLOs:

S.3.K.A.1 Follow simple rules and routines for safe, active participation and use of equipment in selected activities.

Complementary SLOs:

S.4.K.A.2 Sort decisions and/or choices that are made daily, based on their positive or negative consequences.

Activity Outcomes:

Students will be able to:

- Identify safe places for pedestrians and traffic.
 - Make decisions that reflect road safety rules.
-

Suggestions for Instruction:

- Introduce the Activity 13 Worksheet A: *Cut-out figures*, which shows 10 people/traffic objects, to a small group or make an overhead for a class activity.

NOTE: Some of these people and traffic will be seen in different seasons (i.e. spring, summer, fall and winter).

- Introduce Activity 13 Worksheet B: *Safe places*.
 - Discuss where each object may be found, if this is a safe or unsafe place, and what may happen to the object.
 - Ask students to pick 2 people and 2 traffic objects to colour, cut out and glue where they safely belong on Activity 13 Worksheet B: *Safe places*.
 - Discuss with students if this is the safest place for the objects they picked.
-

Suggestions for Assessment:

- Select a few cut-outs and ask students to name safe places for these objects.
-

Cross-Curricular Connections:

- English Language Arts (explore thoughts, ideas, feelings and experiences; manage ideas and information)
 - Social Studies (being together)
 - Science (colours)
-

Opportunities for Family/Community Involvement:

- Invite students to discuss with their parents safe places for pedestrians and traffic in their neighbourhoods.

Instructions: Colour and cut out.

Name: _____

Cut-out figures

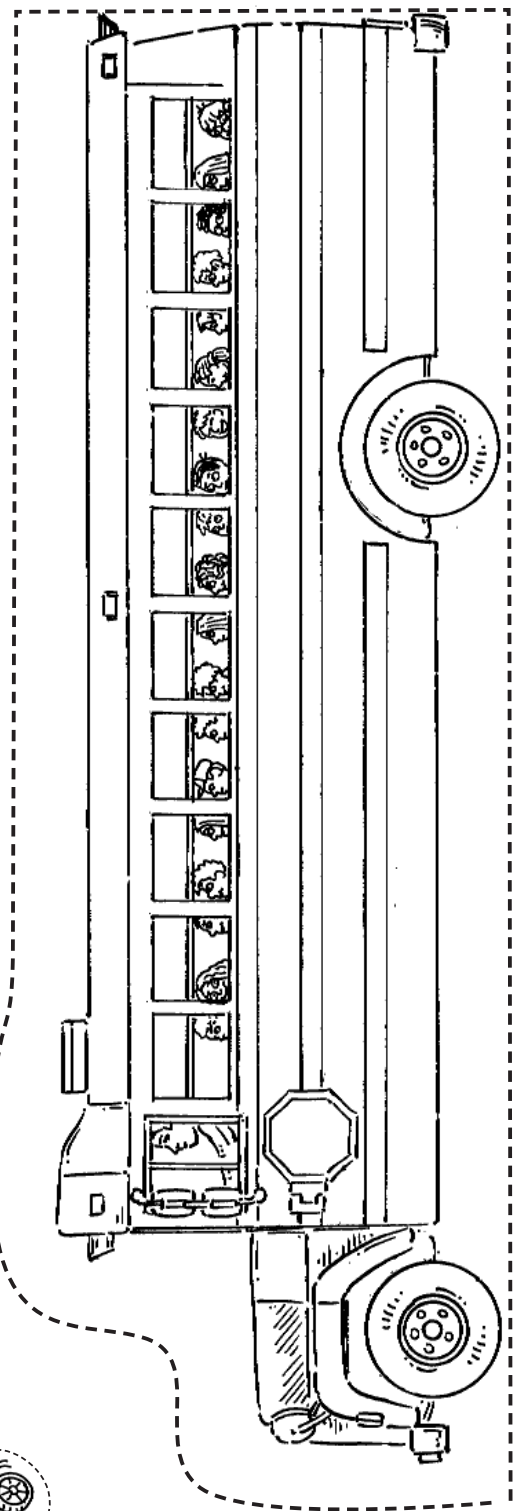
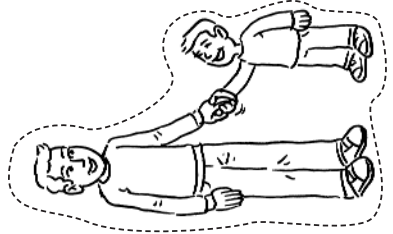
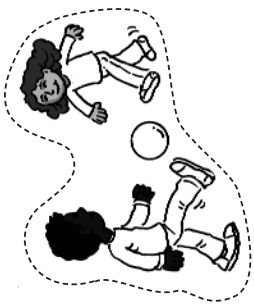
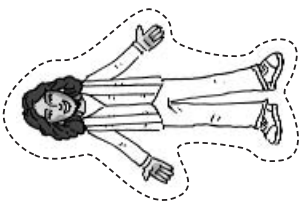
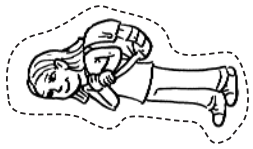
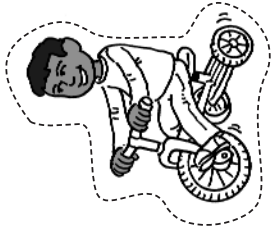
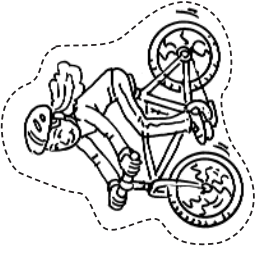
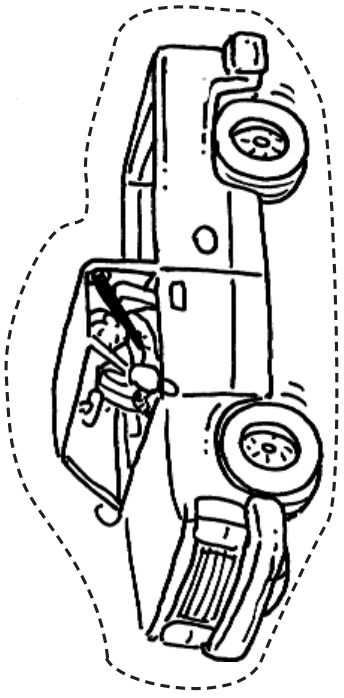
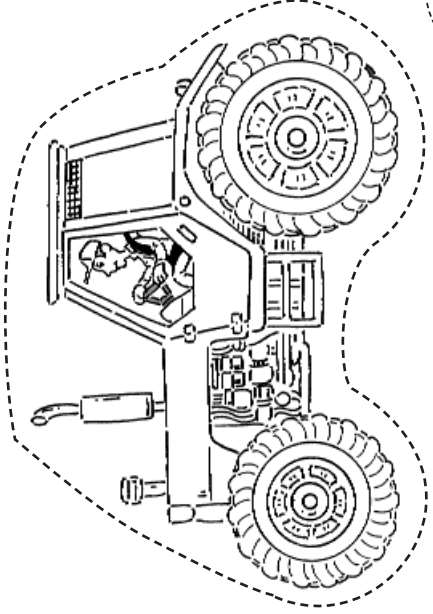

Safe places

Instructions: Glue the cut-outs in safe places.

Name: _____

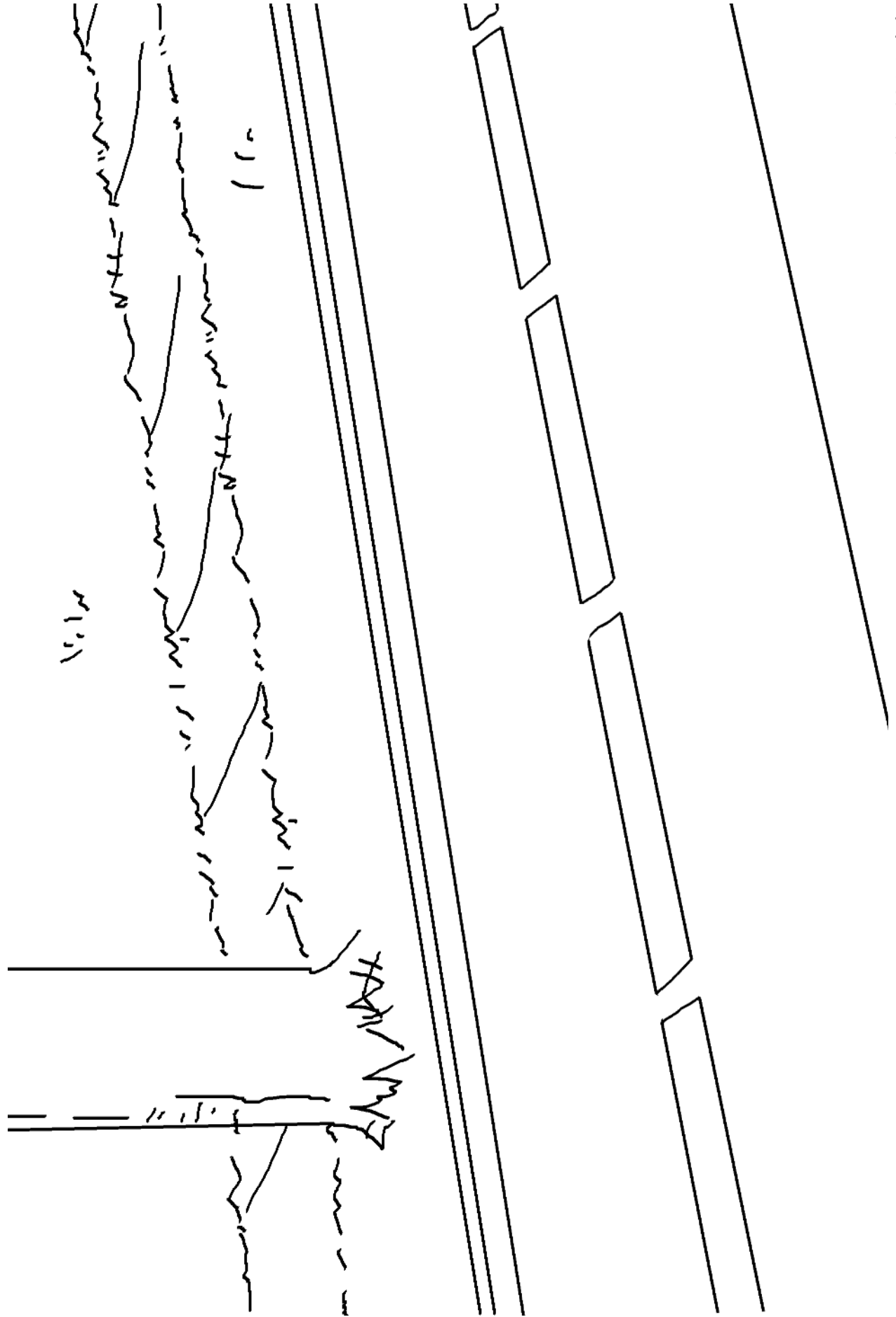

ACTIVITY 14 | *Spy*

Prescribed Learning Outcomes:

Safety SLOs:

K.3.K.B.1 Identify safety symbols, hazards and risks in everyday life (i.e. traffic, school bus ridership).

S.3.K.A.1 Follow simple rules and routines for safe, active participation and use of equipment in selected activities.

Complementary SLOs:

Activity Outcomes:

Students will be able to:

- Identify traffic signs in everyday life.
 - Identify the road safety rules.
-

Suggestions for Instruction:

- Brainstorm on flipchart paper the traffic signs and safety rules. (Refer to Activity 5: *Do you know the road safety rules?*)
 - Introduce Activity 14 Worksheet: *I spy*. This worksheet may be made into an overhead.
 - Brainstorm as a class the traffic signs and safety rules (“dos”) seen in the worksheet.
 - Ask students to circle 2 traffic signs and 3 to 5 safety “dos” (positive safety behaviours) in the worksheet.
(Answers:
 - a) stop sign;
 - b) crosswalk signs;
 - c) children playing in a safe place;
 - d) child holding an adult’s hand;
 - e) adult and child crossing at a crosswalk;
 - f) stop, look and listen and point your arm;
 - g) walking on the sidewalk.)
 - Review the safety rules students may have missed.
-

Suggestions for Assessment:

- The above activity may be used for assessment.
 - Use the Teacher Road Safety Checklist to assess students’ road safety knowledge. (See Assessment Tool.)
-

Cross-Curricular Connections:

- English Language Arts (explore thoughts, ideas, feelings and experiences; enhance the clarity and artistry of communication)
-

Opportunities for Family/Community Involvement:

- Ask students to play *I Spy* around the neighbourhood with their families.

Instructions: Circle traffic signs and safety "dos".

Name: _____

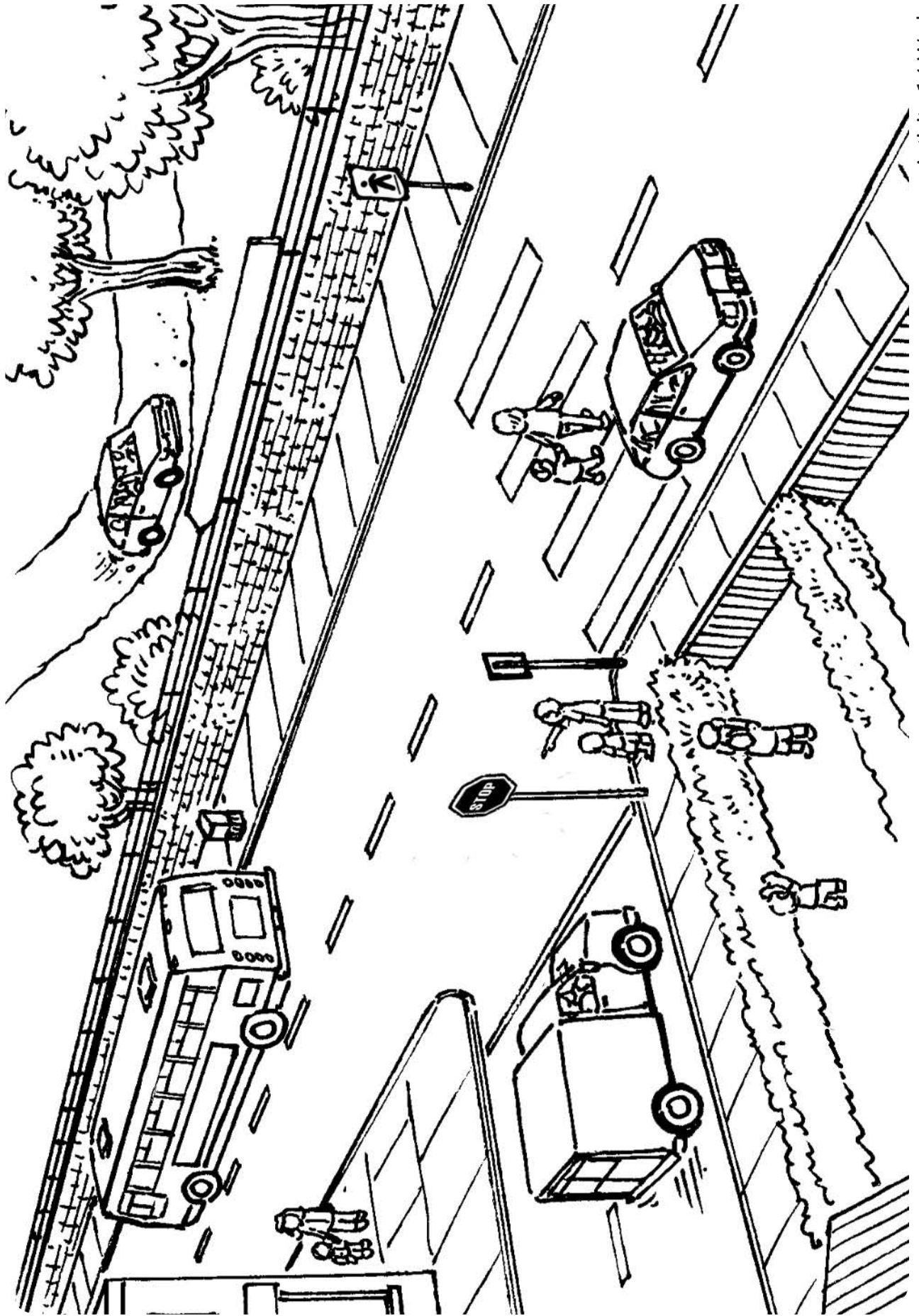

ACTIVITY 15 Practice – Road Safety Walk

Prescribed Learning Outcomes:

Safety SLOs:

- S.3.K.A.1** Follow simple rules and routines for safe, active participation and use of equipment in selected activities.
- K.3.K.A.3** Distinguish between appropriate and inappropriate footwear for indoor and outdoor activities.
- K.3.K.B.3** Identify practices (i.e. follow rules, play in supervised areas, dress appropriately) to prevent injuries related to indoor and outdoor play.

Complementary SLOs:

- K.4.K.A.3** Identify daily decisions and/or choices (e.g. what is safe) and how choices are made for health and well-being.
- S.4.K.A.2** Sort decisions and/or choices that are made daily, based on their positive or negative consequences.
- S.2.K.A.1a** Participate in a wide variety of physical activities that contribute to skill/fitness development and enjoyment.

Activity Outcomes:

Students will be able to:

- Demonstrate basic routines such as correct pedestrian behaviours around road safety.
- Practice making decisions involving road safety.
- Demonstrate practices that prevent injuries related to indoor and outdoor play.
- Identify correct and incorrect footwear for indoor and outdoor activities.
- Participate in various activities that enhance their road safety skills.

Suggestions for Instruction:

NOTE: Ask the Physical Education teacher, older students, or school patrols for help in setting up this activity. Students in Grade 4 may assist as part of Activity 12: *Road Safety Promotion Plan* in the Road Safety Program.

- Construct 1 or 2 mock intersections in different areas of the hall/classroom/gymnasium using existing lines on the floor, some masking tape and pylons.
- Ask 3 helpers (e.g. Grade 4 students or school patrols) to assist at the mock intersections.
- Reproduce and use Activity 15 Visuals A-E: blackline masters of the traffic signs, or use the coloured traffic signs provided.
- Post stop signs on the back of chairs and place at corners of the intersections.
- Post one crosswalk sign along the “road” (lines on the gym floor).
- Have 3 to 4 students pretend to be traffic vehicles. (Optional: Use 4-wheel scooters and have students pretend to put on their seat belts. Listen for the click!)

- Ask students to decide when to safely cross the road while watching for “traffic”.
 - Ask students to complete the Safety Walk, which may include:
 1. crossing the road at a stop sign with an adult and/or friend;
 2. crossing the road at a crosswalk with an adult and/or friend.
 - Have students take turns being the “traffic”.
 - Discuss proper footwear for indoor and outdoor activities.
 - Discuss what you, as the teacher, observed about students’ road safety skills.
-

Suggestions for Assessment:

- Use the Teacher Road Safety Checklist to assess students’ road safety skills during the simulations. (See Assessment Tool.)
-

Cross-Curricular Connections:

- Physical Education/Health Education (movement; personal and social management; fitness management)
 - English Language Arts (manage ideas and information)
-

Opportunities for Family/Community Involvement:

- Send a copy of the road safety rules home for students to discuss with their families.

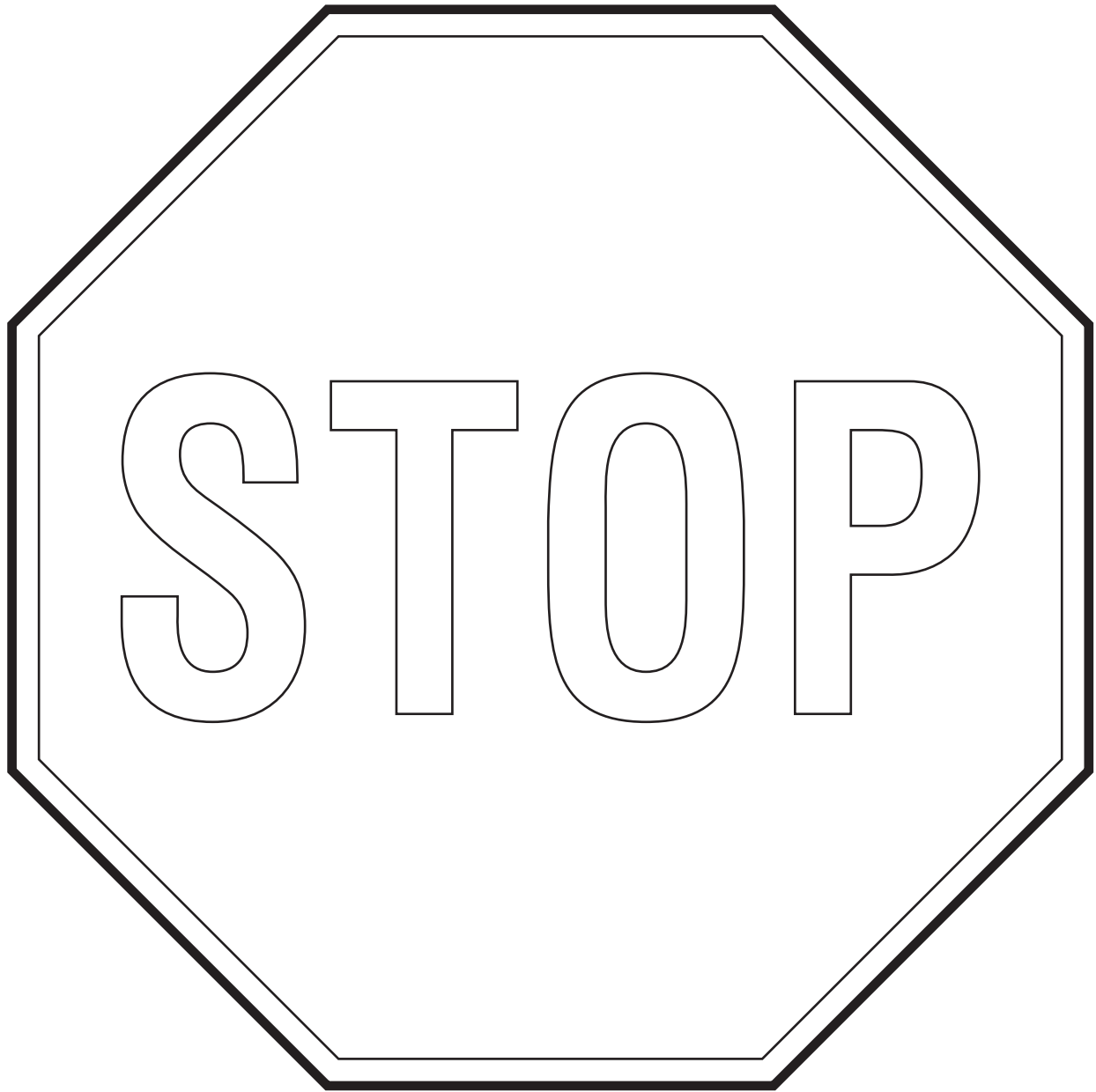

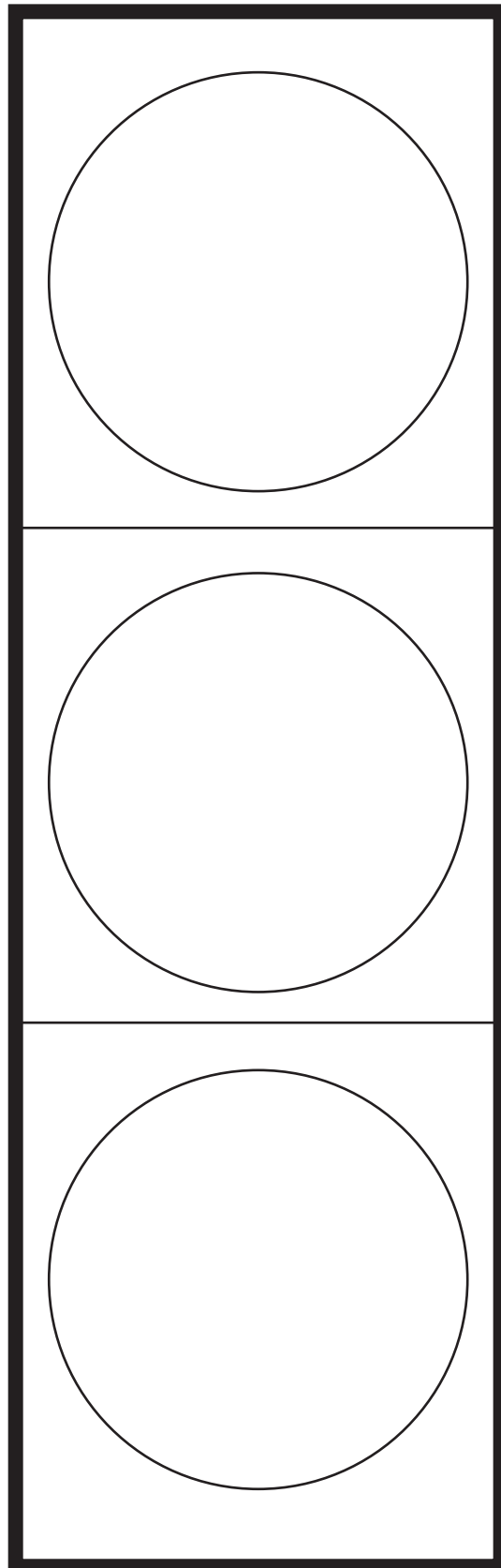





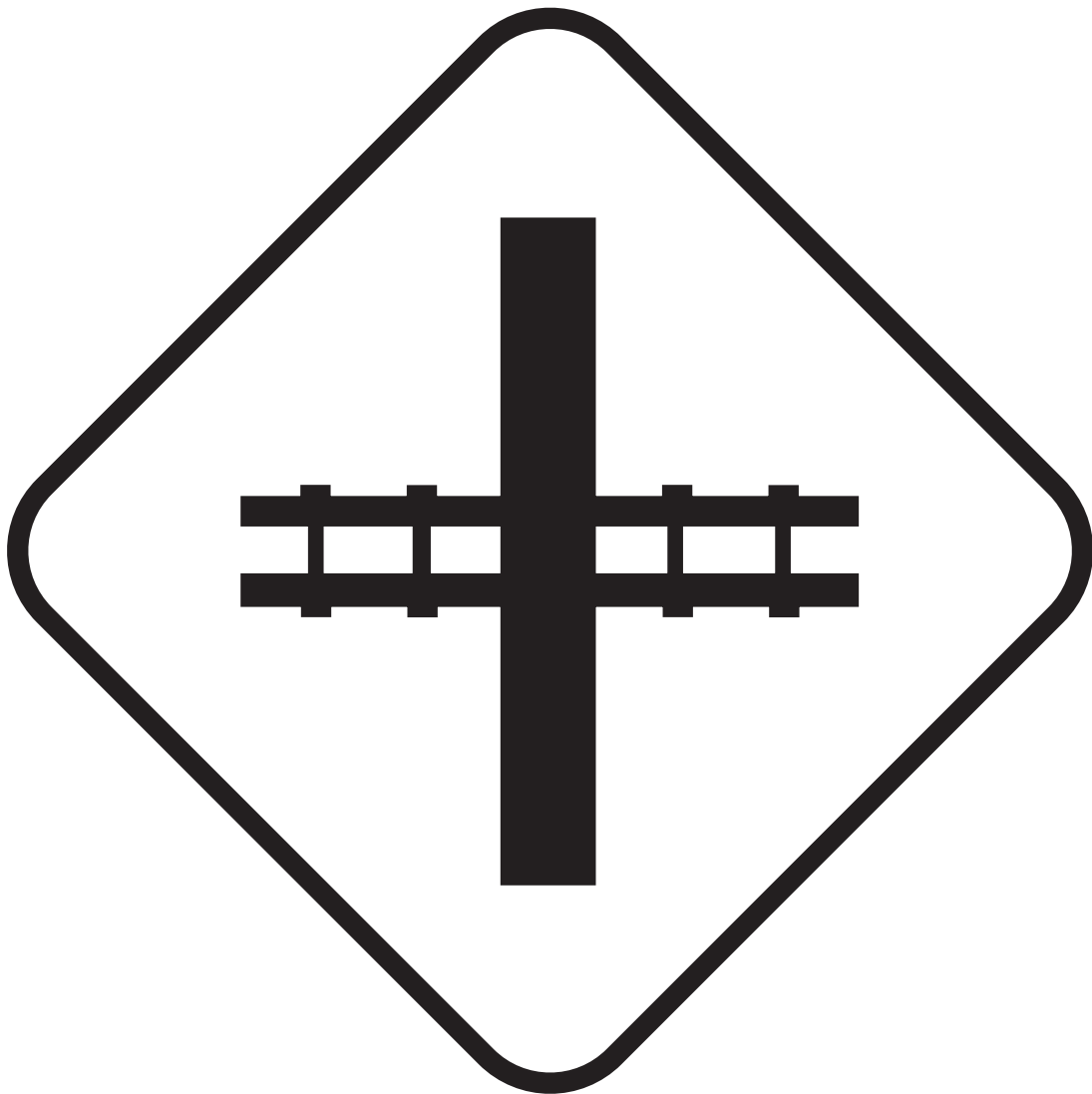

ACTIVITY 16 The Road Safety Walk Game

Prescribed Learning Outcomes:

Safety SLOs:

S.3.K.A.1 Follow simple rules and routines for safe, active participation and use of equipment in selected activities.

K.3.K.B.1 Identify safety symbols, hazards and risks in everyday life.

K.3.K.B.4 Recognize safety helpers in the community.

Complementary SLOs:

Activity Outcomes:

Students will be able to:

- Play a game that reviews the road safety rules, some traffic signs and some safety helpers in the community.
-

Suggestions for Instruction:

NOTE: Students in Grade 4 may assist with the playing of the game as part of Activity 12: *Road Safety Promotion Plan* in the Road Safety Program.

- Introduce Activity 16 Worksheet: *The road safety walk* to a small group or make an overhead for a class activity.
- Explain the game is played by rolling a die, counting the number of spaces and following the instructions.
- Play the game on an overhead with the class.
- Have older students play the game with younger students.

NOTE: The game may be enlarged and laminated for use at a learning station.

Suggestions for Assessment:

- Ask students to name one road safety rule, one traffic sign and one community safety helper.
-

Cross-Curricular Connections:

- Mathematics (number)
 - Social Studies (being together)
 - English Language Arts (celebrate and build community)
-

Opportunities for Family/Community Involvement:

- Invite students to take the Safety Walk Game home and play it with their families.

Instructions: Roll the die, count the spaces and follow instructions.

The road safety walk

Name: _____

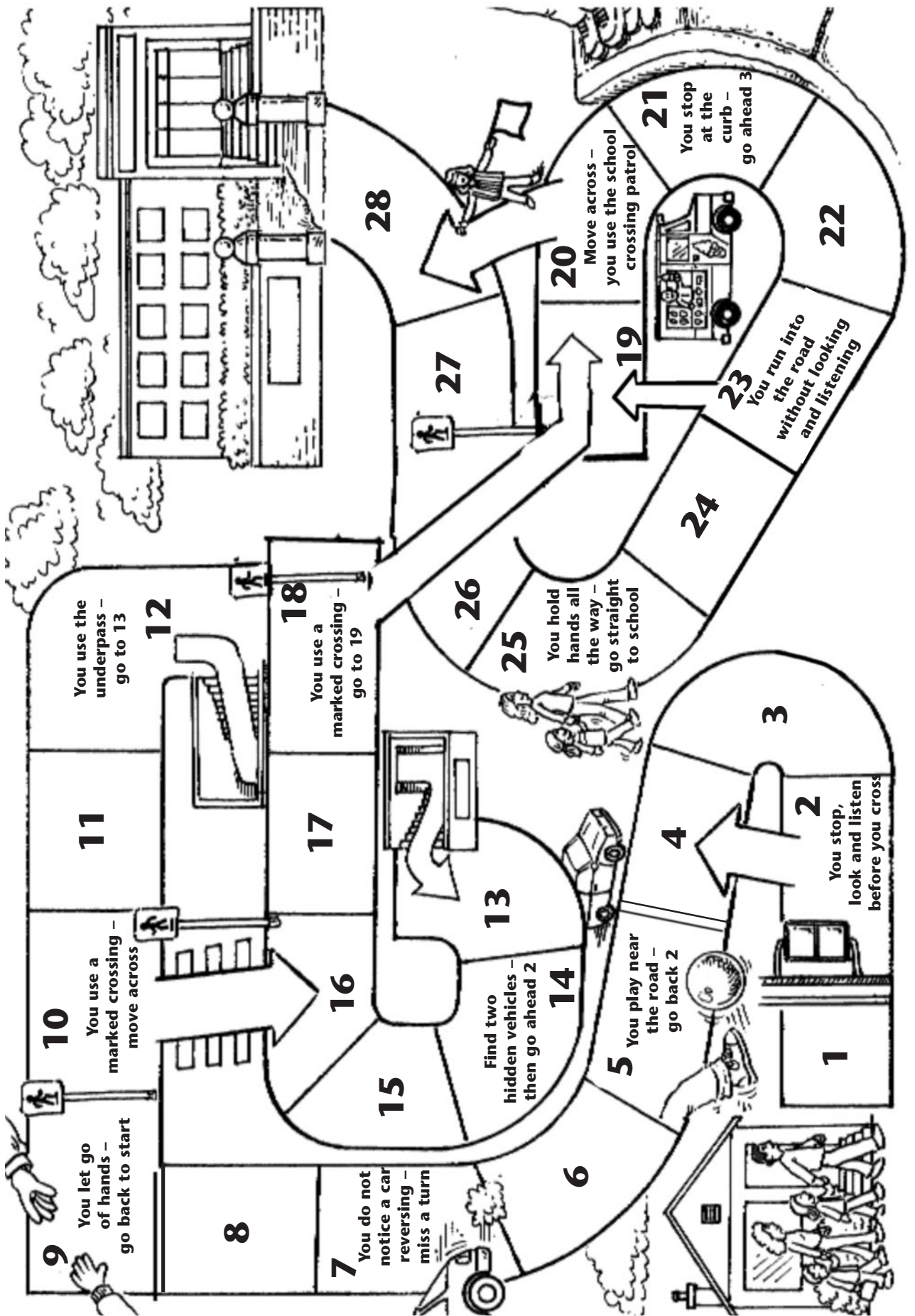

S.3.K.A.1
K.3.K.B.1
K.3.K.B.4

ASSESSMENT TOOL

TEACHER ROAD SAFETY CHECKLIST

Kindergarten

Instructions: This checklist is to be used for ongoing observation in order to determine student progress and to record for assessment purposes.

Students' Names	describes traffic and vehicles Activity 1	names traffic signs and messages Activities 2, 4, 9, 14 & 16	names traffic light colours and messages Activity 3	defines pedestrian Activity 2	names/demonstrates pedestrian safety rules Activities 5, 11, 14 & 15	names/demonstrates vehicle passenger safety rules Activities 5 & 14	demonstrates sequence for crossing road safely Activity 6

TEACHER ROAD SAFETY CHECKLIST Kindergarten

Instructions: This checklist is to be used for ongoing observation in order to determine student progress and to record for assessment purposes.

Students' Names	name road dangers and why dangerous Activities 7 & 8	names type of safety helpers and jobs Activities 10, 11 & 16	names safe and unsafe places to play Activities 12 & 13	names consequences of playing in safe and unsafe places Activity 12	makes safe decisions around road Activities 13 & 15	names correct and incorrect footwear for indoor and outdoor Activity 15	participates in activities that enhance road safety skills Activities 6, 9, 15 & 16